

1-Line Unidirectional ESD Protection Diode

Description

Unidirectional ElectroStatic Discharge (ESD) protection diode in a SOD523 plastic package designed to protect one transmission or data line from the damage caused by ESD and other transients.

Features

- Unidirectional ESD protection of one line
- Reverse stand-off voltage: 12V Max
- Low leakage current: nA Level
- Response time is typically < 1 ns
- Low clamping voltage: VC < 23 V @ IPP = 6.3A
- ESD Protection: 15kV(air)/ 8kV(contact)
(IEC61000-4-2)
- Surge Protection: 5.5A (IEC 61000-4-5 8/20 μ s)

Schematic and Pin Configuration

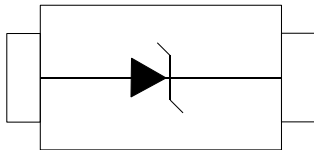

Graphic symbol

Applications

- Cellular phones
- Portable devices
- Digital cameras
- Power supplies

Marking Information



ZM= Device Marking Code

Ordering nformation

Part Number	Packaging	Package
PESDU1201D5N	3000/Tape & Reel	SOD523

Absolute Maximum Ratings (T_A=25°C unless otherwise specified)

Parameter	Symbol	Value	Unit
Peak Pulse Power (8/20μs)	P _{PK}	140	W
Peak Pulse Current (8/20μs)	I _{PP}	5.5	A
ESD per IEC 61000-4-2 (Air)	V _{ESD}	± 15	kV
ESD per IEC 61000-4-2 (Contact)		± 8	
Operating Temperature Range	T _{OP}	-55 to +125	°C
Storage Temperature Range	T _{STG}	-55 to +150	°C

Electrical Characteristics (T_A=25°C unless otherwise specified)

Parameter	Symbol	Min	Typ	Max	Unit	Test Condition
Reverse Working Voltage	V _{RWM}			12	V	Any I/O pin to ground
Breakdown Voltage	V _{BR}	13.5			V	I _T = 1mA, any I/O pin to ground
Reverse Leakage Current	I _R			100	nA	V _{RWM} = 12V, any I/O pin to ground
Clamping Voltage	V _C			25	V	I _{PP} = 5.5A (8/20μs pulse)
Junction Capacitance	C _J			55	pF	V _R = 0V, f = 1MHz

Typical Performance Characteristics (T_A=25°C unless otherwise Specified)

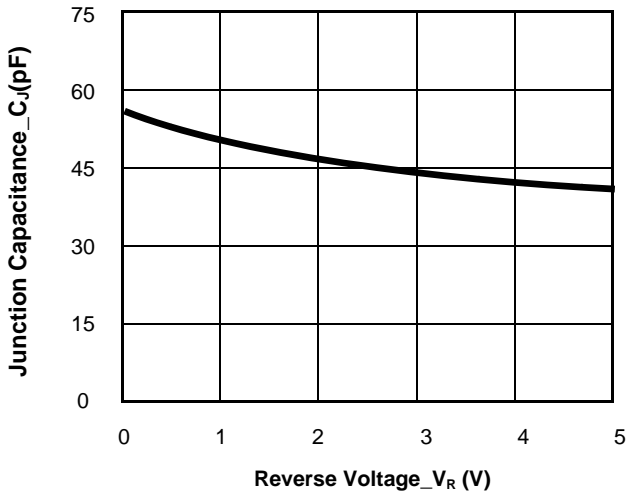

Junction Capacitance vs. Reverse Voltage

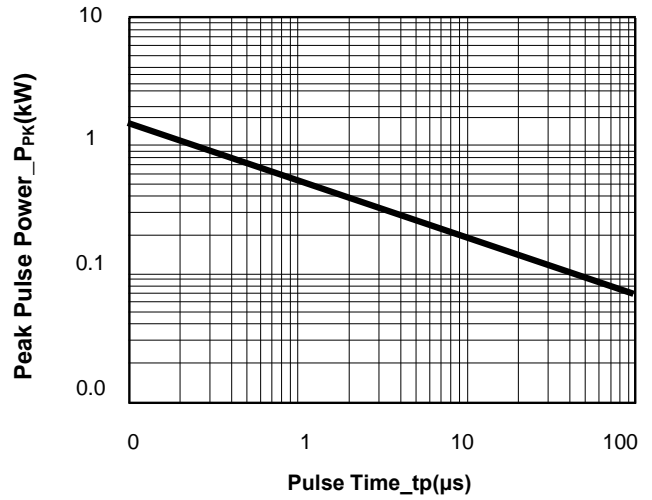

Peak Pulse Power vs. Pulse Time

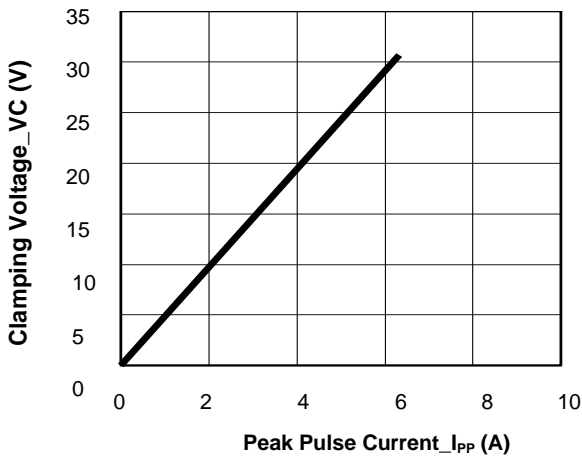

Clamping Voltage vs. Peak Pulse Current

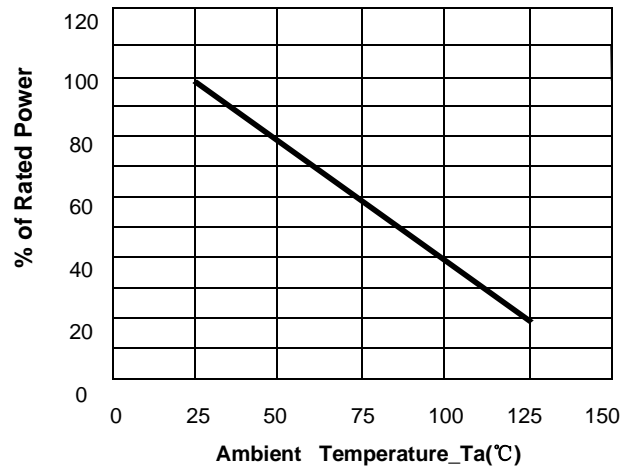

Power Derating Curve

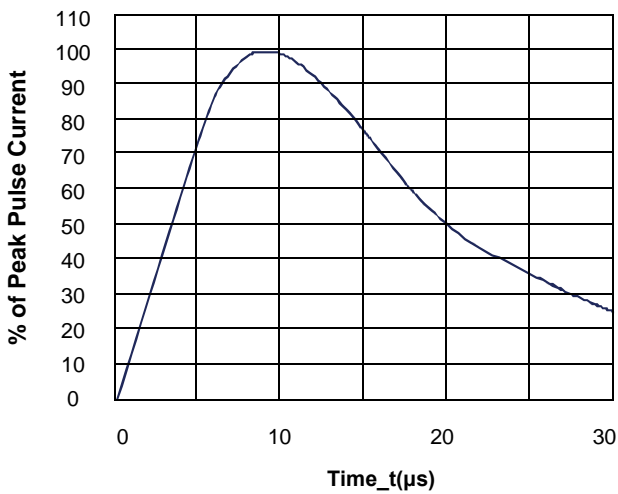

8/20μs Pulse Waveform

SOD523 Package Outline Drawing

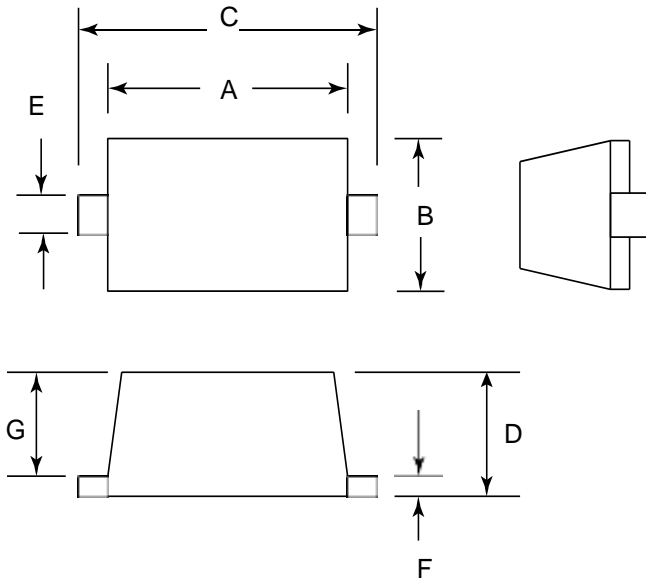

SYM	DIMENSIONS			
	MILLIMETERS		INCHES	
	MIN	MAX	MIN	MAX
A	1.10	1.30	0.043	0.051
B	0.70	0.90	0.028	0.035
C	1.50	1.70	0.059	0.067
D	0.50	0.70	0.020	0.028
E	0.25	0.35	0.010	0.014
F	0.10	0.20	0.004	0.008
G	0.50	0.70	0.020	0.028

Suggested Land Pattern

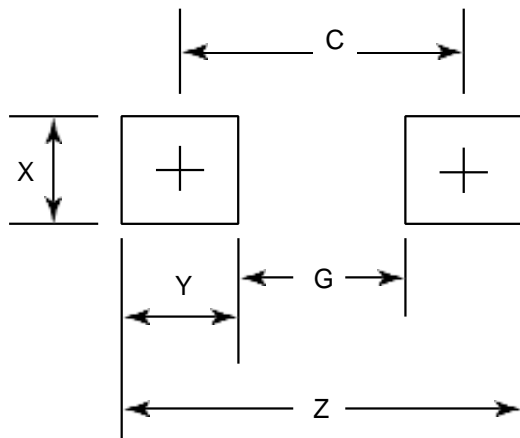

SYM	DIMENSIONS	
	MILLIMETERS	INCHES
C	1.70	0.067
G	1.10	0.043
X	0.80	0.031
Y	0.60	0.024
Z	2.30	0.091