

4-Line Low Capacitance TVS Diode Array

Description

The PESDR0554S2-7A is a low capacitance TVS array, to provide fast response time and low ESD clamping voltage, making this device an ideal solution for protecting voltage sensitive high-speed data lines. The PESDR0554S2-7A has an ultra-low capacitance, and complies with the IEC 61000-4-2 (ESD) standard with $\pm 25\text{kV}$ air and $\pm 20\text{kV}$ contact discharge. It is assembled into a 6-Pin lead-free SOT-23-6 package. The low capacitance array make it ideal for four high speed data and transmission line. This device is optimized for ESD protection of portable electronics.

Features

- Ultra low leakage: nA level
- Low operating voltage: 5V
- Low clamping voltage
- Up to 4 lines and one power line protects
- Complies with following standards:
 - IEC 61000-4-2 (ESD) immunity test
Air discharge: $\pm 25\text{kV}$
Contact discharge: $\pm 20\text{kV}$
 - IEC61000-4-4 (EFT) 55A (5/50ns)
 - IEC61000-4-5 (Lightning) 7A (8/20 μs)
- RoHS Compliant

Dimensions and Pin Configuration

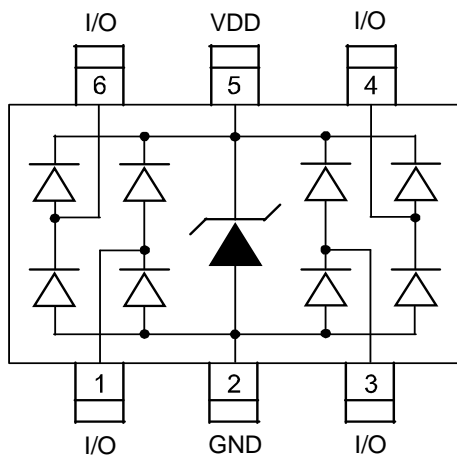

Circuit and Pin Schematic

Mechanical Characteristics

- Package: SOT-23-6
- Lead Finish: Matte Tin
- Case Material: “Green” Molding Compound
- Moisture Sensitivity: Level 3 per J-STD-020
- Marking Information: See Below

Applications

- Video/Graphics Card
- Digital Visual Interface (DVI)
- USB2.0 Power and Data lines protection
- Notebook and PC Computers
- Monitors and Flat Panel Displays

Marking Information

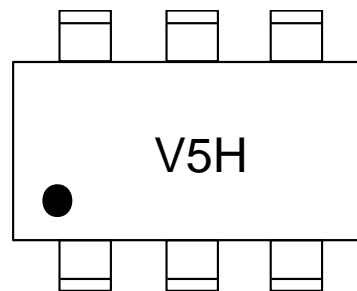

V5H = Device Marking Code
Dot denotes Pin1

Ordering Information

Part Number	Shipping	Reel Size
PESDR0554S2-7A	3000/Tape & Reel	7 inch

Absolute Maximum Ratings ($T_A=25^{\circ}\text{C}$ unless otherwise specified)

Parameter	Symbol	Value	Unit
Peak Pulse Power (8/20 μs)	P _{PK}	120	W
Peak Pulse Current (8/20 μs)	I _{PP}	7	A
ESD per IEC 61000-4-2 (Air)	V _{ESD}	± 30	kV
ESD per IEC 61000-4-2 (Contact)		± 30	
Operating Temperature Range	T _{OP}	-55 to +125	$^{\circ}\text{C}$
Storage Temperature Range	T _{STG}	-55 to +150	$^{\circ}\text{C}$

Electrical Characteristics ($T_A=25^{\circ}\text{C}$ unless otherwise specified)

Parameter	Symbol	Min	Typ	Max	Unit	Test Condition
Reverse Working Voltage	V _{RWM}			5.0	V	Any I/O pin to ground
Breakdown Voltage	V _{BR}	6.0			V	I _T = 1mA, any I/O pin to ground
Reverse Leakage Current	I _R			5	μA	V _{RWM} = 5V, any I/O pin to ground
Forward Voltage	V _F		0.8	1.0	V	I _T =10mA
Clamping Voltage	V _C		14.5	17.5	V	I _{PP} = 7A (8/20 μs pulse), any I/O pin to ground
Junction Capacitance	C _J		0.7		pF	V _R = 0V, f = 1MHz, any I/O pin to ground

Typical Performance Characteristics ($T_A=25^\circ\text{C}$ unless otherwise Specified)

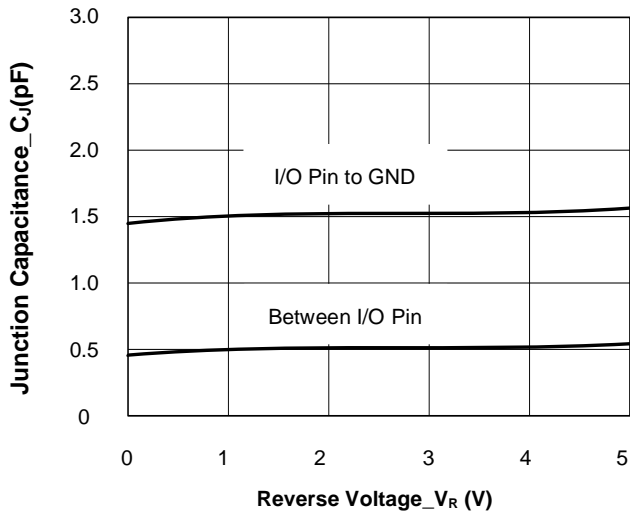

Junction Capacitance vs. Reverse Voltage

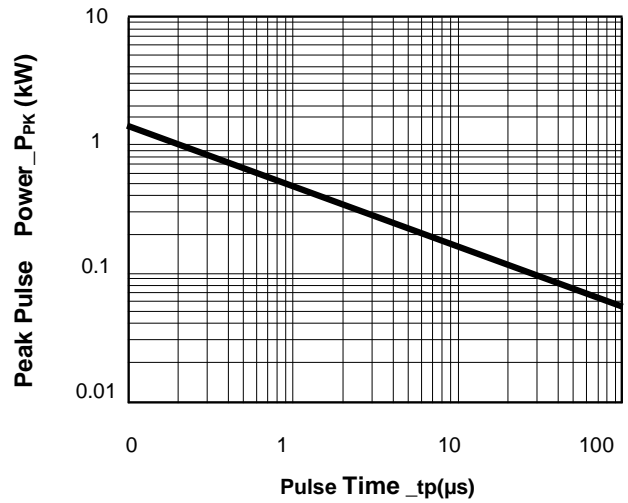

Peak Pulse Power vs. Pulse Time

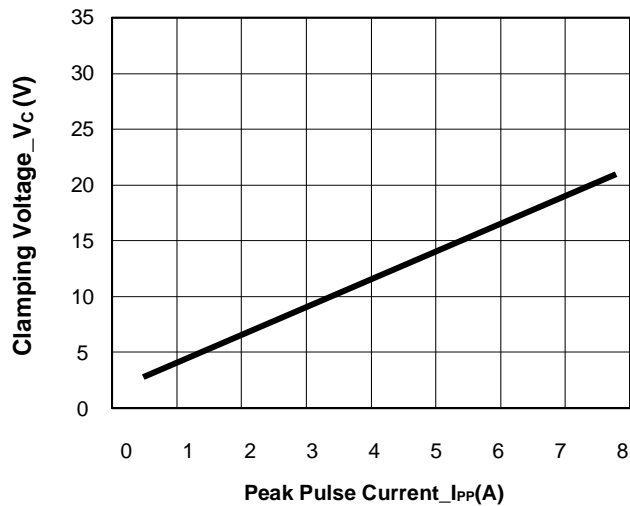

Clamping Voltage vs. Peak Pulse Current

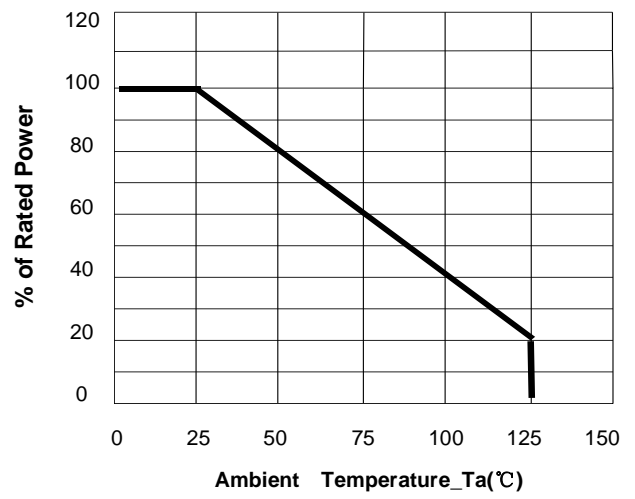

Power Derating Curve

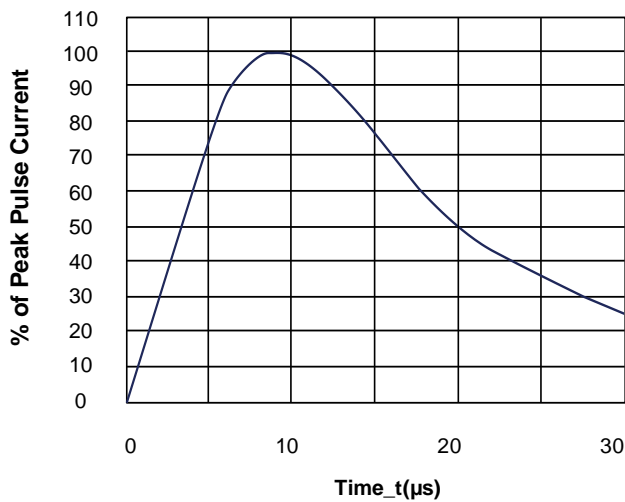

8/20μs Pulse Waveform

Typical Application

The PESDR0554S2-7A is designed to protect four data lines from transient over-voltages by clamping them to fixed reference. When the voltage on the protected line exceeds the reference voltage (plus diode V_F) the steering diodes are forward biased, conducting the transient current away from the sensitive circuitry. Data lines are connected at pins 1, 3, 4 and 6. The negative reference (REF1) is connected at pin 2. This pin should be connected directly to a ground plane on the board for best results. The path length is kept as short as possible to minimize parasitic inductance. The positive reference (REF2) is connected at pin 5.

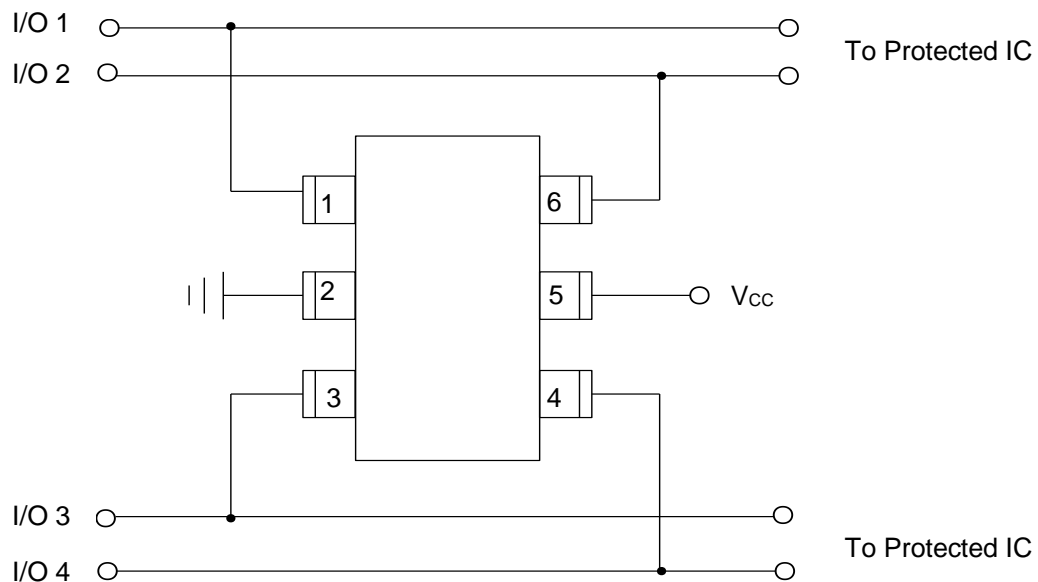

PESDR0554S2-7A on USB 3.0 Port Application

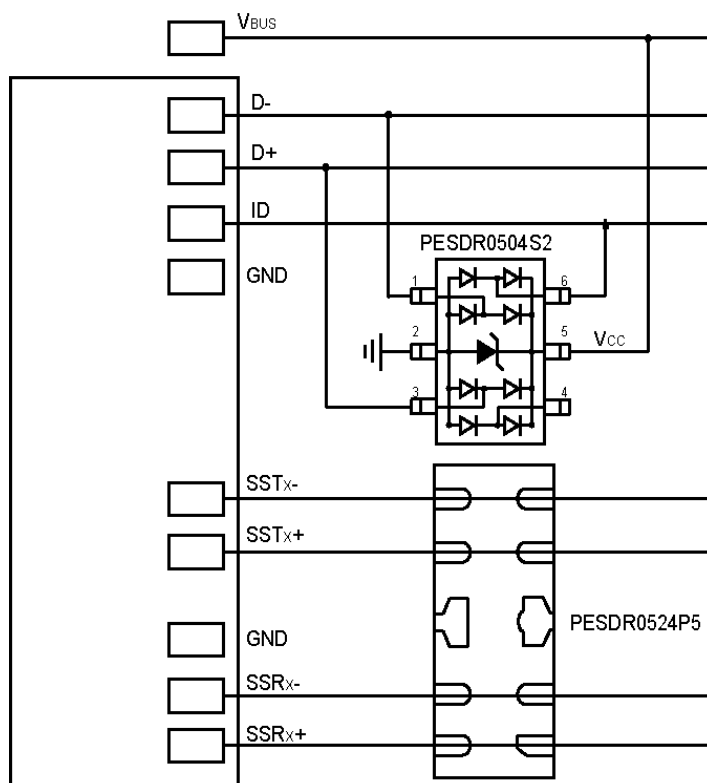

PESDR0554S2-7A on HDMI Port Application

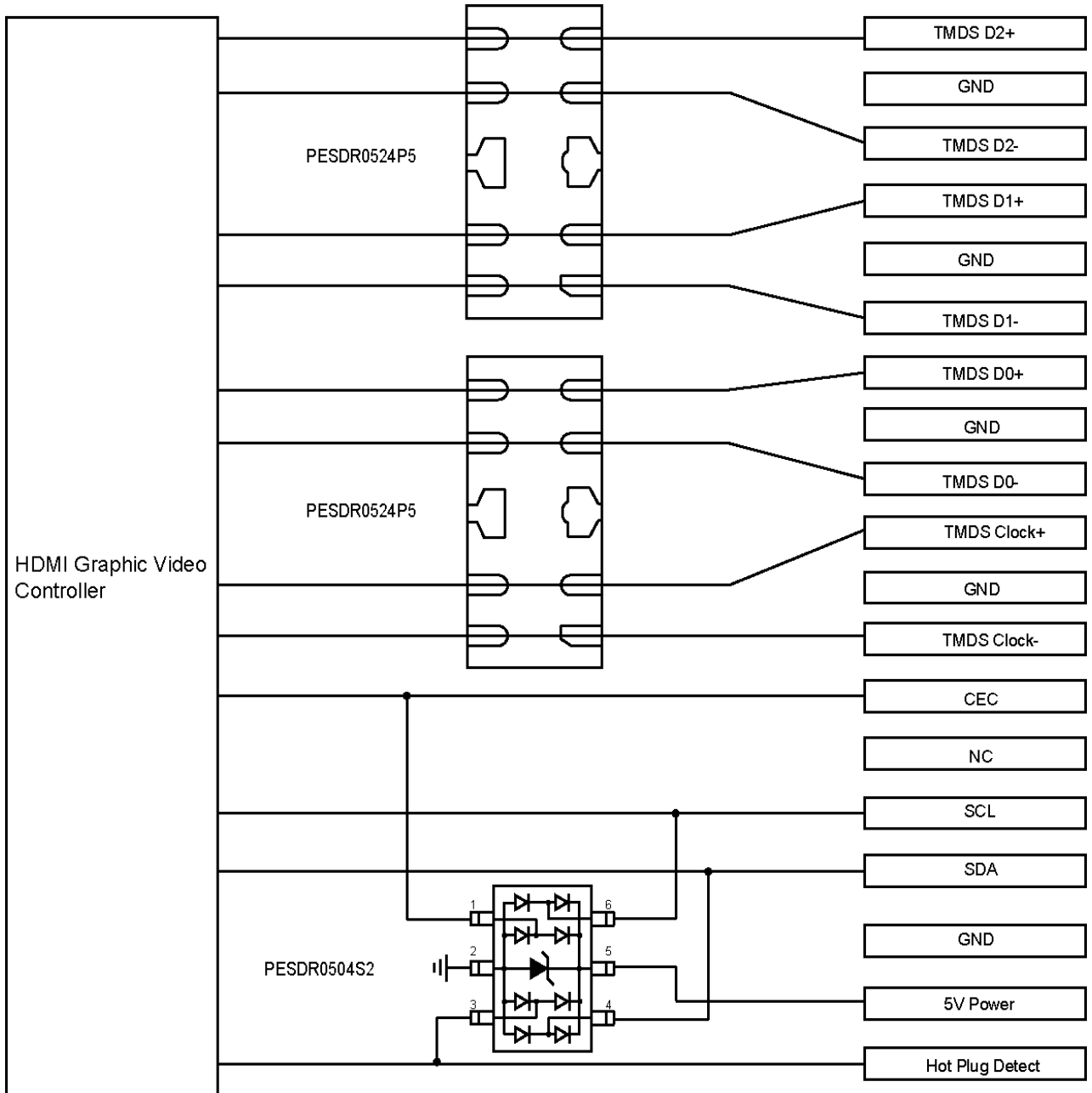

SOT-23-6 Package Outline Drawing

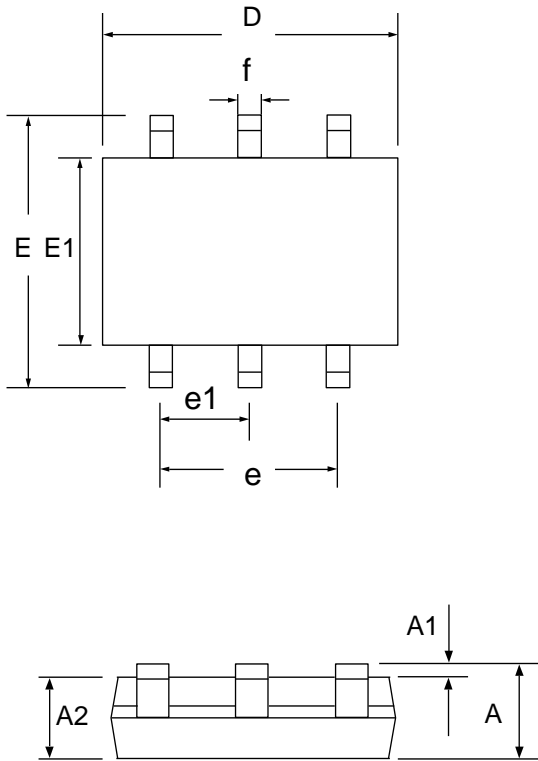

SYM	DIMENSIONS					
	MILLIMETERS			INCHES		
	MIN	NOM	MAX	MIN	NOM	MAX
A	0.90		1.45	0.035		0.057
A1	0.00		0.15	0.000		0.006
A2	0.90	1.15	1.30	0.035	0.045	0.051
D	2.80	2.90	3.10	0.110	0.114	0.122
E	2.80 BSC			0.110 BSC		
E1	1.50	1.60	1.75	0.060	0.063	0.069
e	1.90 BSC			0.075 BSC		
e1	0.95 BSC			0.037 BSC		
f	0.30		0.50	0.012		0.020

Suggested Land Pattern

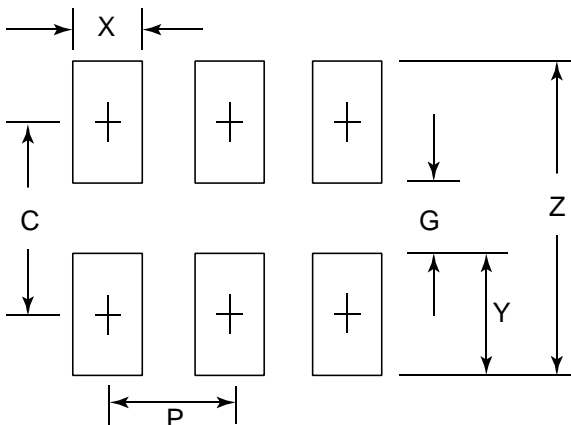

SYM	DIMENSIONS	
	MILLIMETERS	INCHES
C	2.50	0.098
G	1.40	0.055
P	0.95	0.037
X	0.60	0.024
Y	1.10	0.043
Z	3.60	0.141