

**1-Line, Uni-directional, Transient Voltage Suppressor**

**Descriptions**

The PESDU2201P1 is a uni-directional TVS (Transient Voltage Suppressor). It is specifically designed to protect sensitive electronic components that may be subjected to ESD (Electrostatic Discharge), EFT (Electrical Fast Transients) and Lightning. It is particularly well-suited for cellular phones, portable device, digital cameras, power supplies and many other portable applications because of its small package and low weight.

The PESDU2201P1 may be used to provide ESD protection up to ±30kV (contact discharge) according to IEC61000-4-2, and withstand peak pulse current up to 9A (8/20µs) according to IEC61000-4-5.

The PESDU2201P1 is available in DFN1006-2L package. Standard products are Pb-free and Halogen-free.

**Features**

- Stand-off voltage: 2.2V Max.
- Transient protection for each line according to IEC61000-4-2 (ESD): ±30kV (contact discharge)  
IEC61000-4-4 (EFT): 40A (5/50ns)  
IEC61000-4-5 (surge): 9A (8/20µs)
- Capacitance: C<sub>J</sub> = 5pF Typ.
- Solid-state silicon technology

**Applications**

- Cell phone handsets and accessories
- Personal Digital Assistants (PDAs)
- Notebooks, Desktops, and Servers
- Portable Instrumentation
- Digital Cameras
- Power supply protection
- Power management

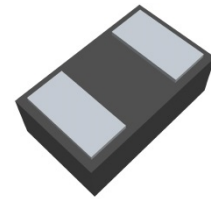

**DFN1006-2L**

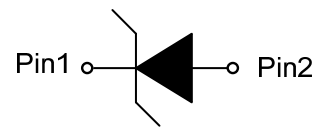

**Circuit diagram**



H = Device code  
\* = Date code (A~Z)

**Marking (Top View)**

**Order information**

Device	Package	Shipping
PESDU2201P1	DFN1006-2L	10000/Tape&Reel

**Absolute maximum ratings**

Parameter	Symbol	Rating	Unit
Peak pulse power ( $t_p = 8/20\mu s$ )	$P_{pk}$	72	W
Peak pulse current ( $t_p = 8/20\mu s$ )	$I_{PP}$	9	A
ESD according to IEC61000-4-2 air discharge	$V_{ESD}$	$\pm 30$	kV
ESD according to IEC61000-4-2 contact discharge		$\pm 30$	
Junction temperature	$T_J$	125	$^{\circ}C$
Operating temperature	$T_{OP}$	-40~85	$^{\circ}C$
Lead temperature	$T_L$	260	$^{\circ}C$
Storage temperature	$T_{STG}$	-55~150	$^{\circ}C$

**Electrical characteristics ( $T_A = 25^{\circ}C$ , unless otherwise noted)**

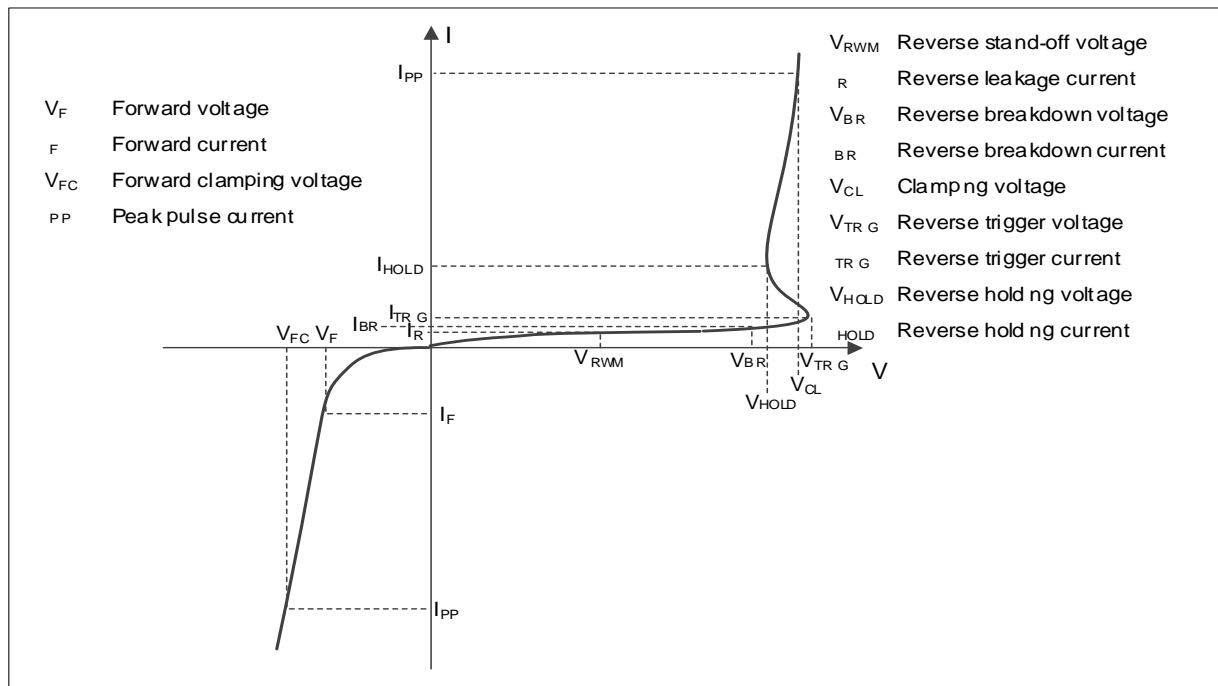

**Definitions of electrical characteristics**

**Electrical characteristics ( $T_A = 25^\circ\text{C}$ , unless otherwise noted)**

Parameter	Symbol	Condition	Min.	Typ.	Max.	Unit
Reverse stand-off voltage	$V_{RWM}$				2.2	V
Reverse leakage current	$I_R$	$V_{RWM} = 2.2\text{V}$			0.1	$\mu\text{A}$
Reverse breakdown voltage	$V_{BR}$	$I_T = 1\text{mA}$	2.6	2.8	3.0	V
Forward voltage	$V_F$	$I_F = 20\text{mA}$	0.6	0.8	1.1	V
Clamping voltage <sup>1)</sup>	$V_{CL}$	$I_{PP} = 16\text{A}$ , $t_p = 100\text{ns}$		7.5		V
Clamping voltage <sup>2)</sup>	$V_{CL}$	$V_{ESD} = 8\text{kV}$		7.5		V
Clamping voltage <sup>3)</sup>	$V_C$	$I_{pp}=1\text{A}$ $t_p=8/20\mu\text{s}$			5	V
		$I_{pp}=9\text{A}$ $t_p=8/20\mu\text{s}$			8	V
Dynamic resistance <sup>1)</sup>	$R_{DYN}$			0.22		$\Omega$
Junction capacitance	$C_J$	$V_R = 0\text{V}$ , $f = 1\text{MHz}$		5	6.5	pF

Notes:

- 1) TLP parameter:  $Z_0 = 50\Omega$ ,  $t_p = 100\text{ns}$ ,  $t_r = 2\text{ns}$ , averaging window from 60ns to 80ns.  $R_{DYN}$  is calculated from 4A to 16A.
- 2) Contact discharge mode, according to IEC61000 4 2.
- 3) Non repetitive current pulse, according to IEC61000 4 5.

**Typical characteristics (T<sub>A</sub>=25°C, unless otherwise noted)**

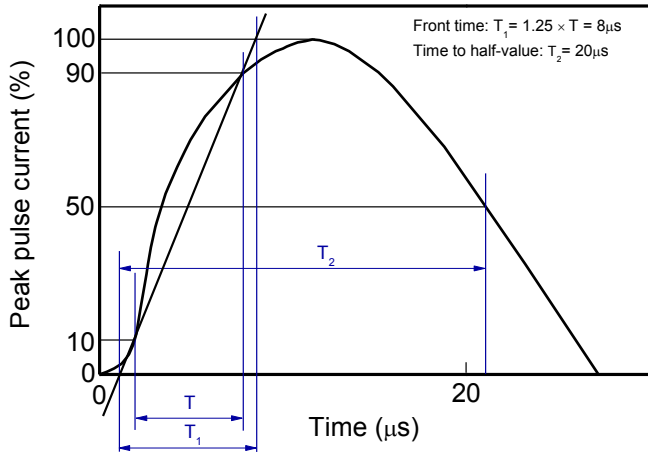

**8/20μs waveform per IEC61000-4-5**

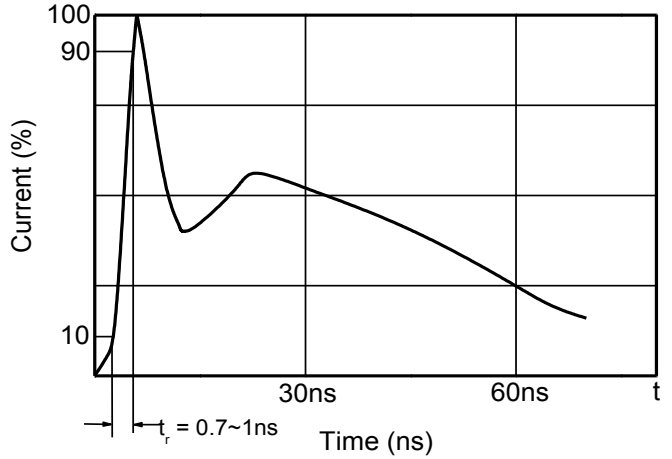

**Contact discharge current waveform per IEC61000-4-2**

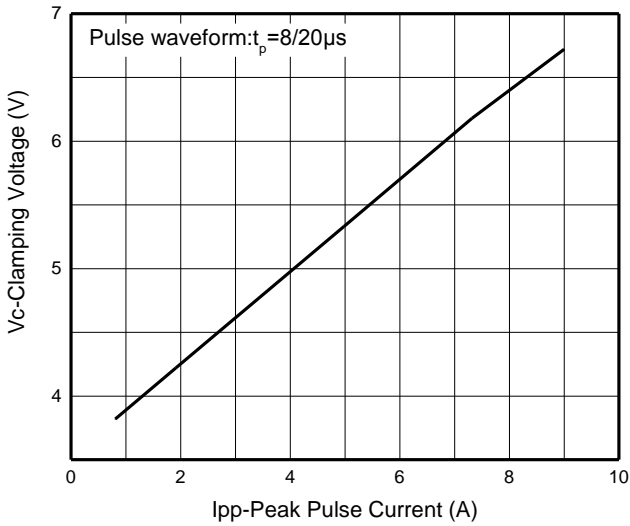

**Clamping voltage vs. Peak pulse current**

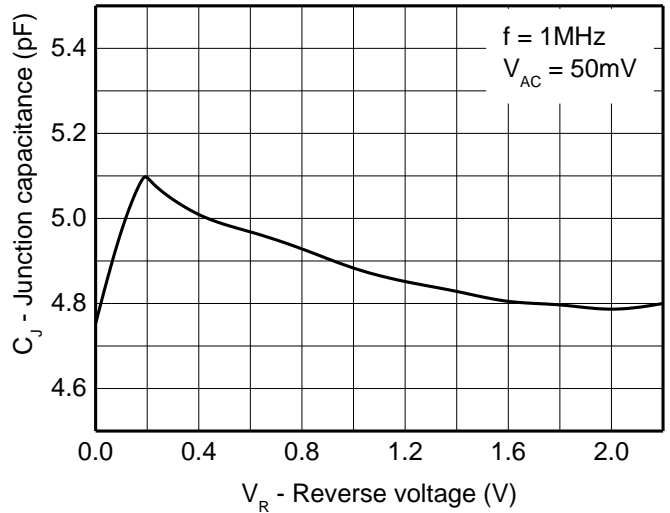

**Capacitance vs. Reverse voltage**

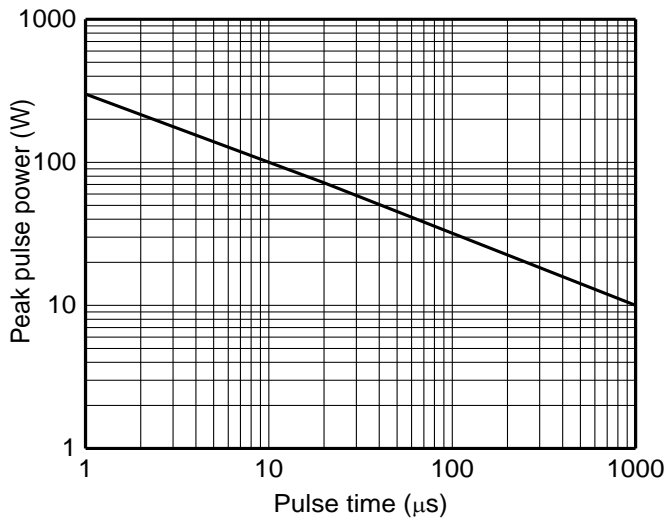

**Non-repetitive peak pulse power vs. Pulse time**

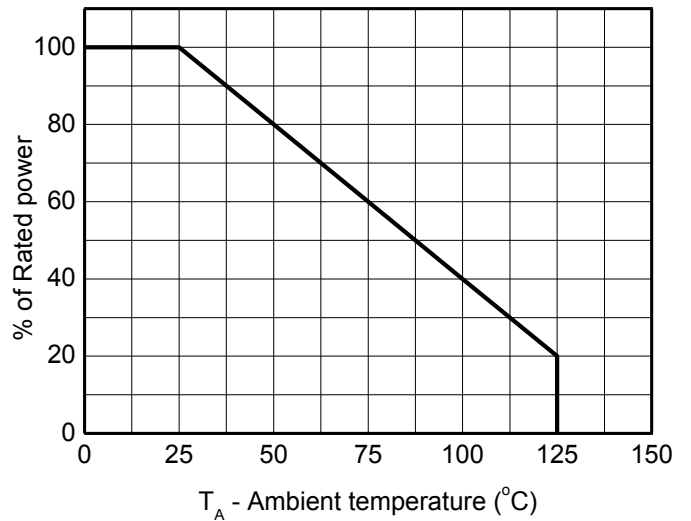

**Power derating vs. Ambient temperature**

Typical characteristics ( $T_A=25^{\circ}\text{C}$ , unless otherwise noted)

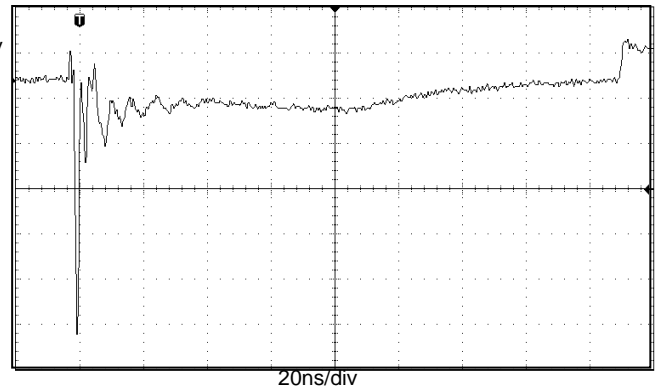
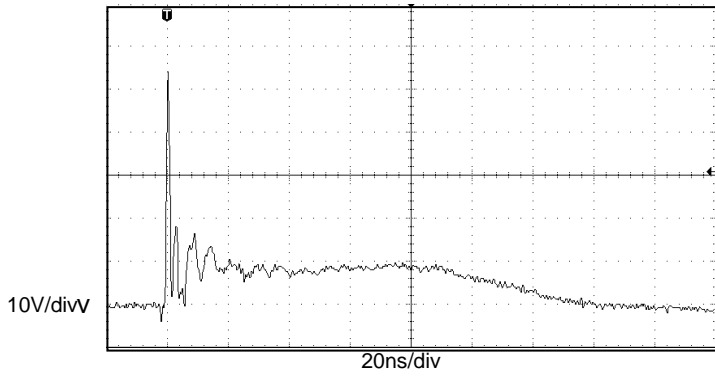

**ESD clamping**  
(+8kV contact discharge per IEC61000-4-2)

**ESD clamping**  
(-8kV contact discharge per IEC61000-4-2)

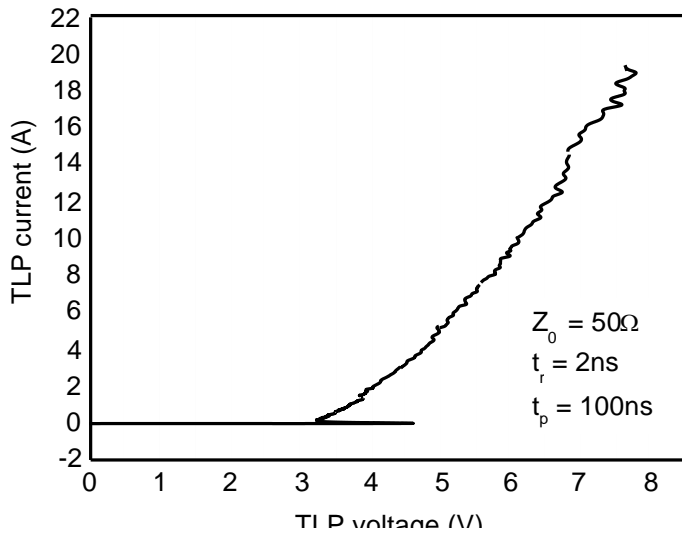

**TLP Measurement**

**PACKAGE OUTLINE DIMENSIONS**

**DFN1006-2L**

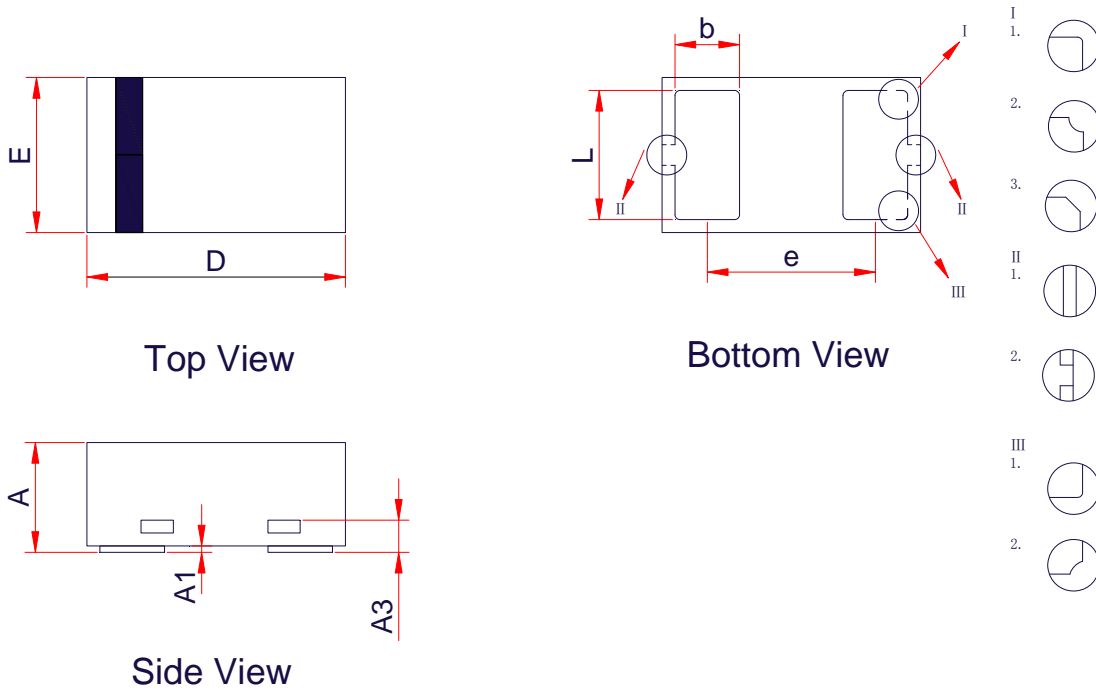

Symbol	Dimensions in Millimeters		
	Min.	Typ.	Max.
A	0.34	0.45	0.53
A1	0.00	0.02	0.05
A3	0.12 Ref.		
D	0.95	1.00	1.08
E	0.55	0.60	0.68
b	0.20	0.25	0.30
L	0.45	0.50	0.55
e	0.65 BSC		

**Recommended land pattern (Unit: mm)**

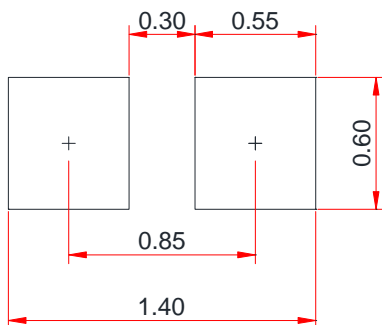

**Notes:**

This recommended land pattern is for reference purposes only. Please consult your manufacturing group to ensure your PCB design guidelines are met.

**TAPE AND REEL INFORMATION**

**Reel Dimensions**

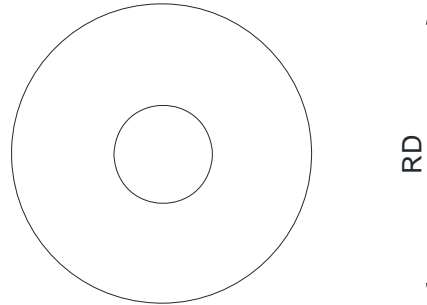

**Tape Dimensions**

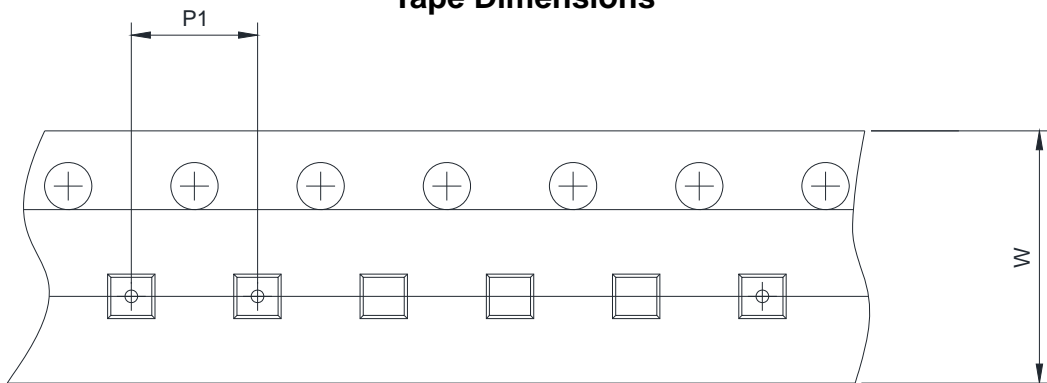

**Quadrant Assignments For PIN1 Orientation In Tape**

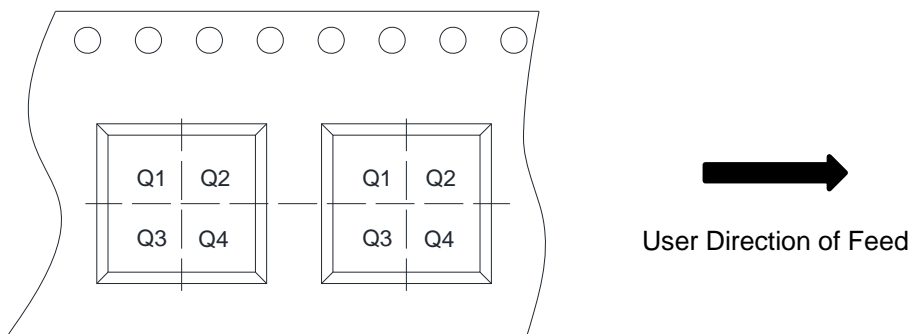

RD	Reel Dimension	<input checked="" type="checkbox"/> 7inch	<input type="checkbox"/> 13inch
W	Overall width of the carrier tape	<input checked="" type="checkbox"/> 8mm	<input type="checkbox"/> 12mm <input type="checkbox"/> 16mm
P1	Pitch between successive cavity centers	<input checked="" type="checkbox"/> 2mm	<input type="checkbox"/> 4mm <input type="checkbox"/> 8mm
Pin1	Pin1 Quadrant	<input checked="" type="checkbox"/> Q1	<input checked="" type="checkbox"/> Q2 <input type="checkbox"/> Q3 <input type="checkbox"/> Q4