

**FEATURES**

The plastic package carries Underwriters Laboratory Flammability Classification 94V-0  
 For surface mounted applications  
 Low reverse leakage  
 Built-in strain relief, ideal for automated placement  
 High forward surge current capability  
 High temperature soldering guaranteed:  
 250°C/10 seconds at terminals  
 Glass passivated chip junction

**MECHANICAL DATA**

**Case:** JEDEC DO-214AA molded plastic body over passivated chip  
**Terminals:** Solder plated, solderable per MIL-STD-750, Method 2026  
**Polarity:** Color band denotes cathode end  
**Mounting Position:** Any  
**Weight:** 0.007 ounce, 0.25grams

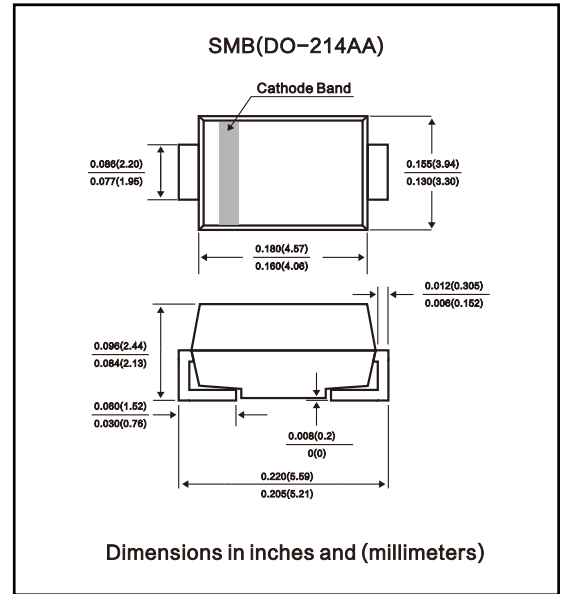

**MAXIMUM RATINGS AND ELECTRICAL CHARACTERISTICS**

(single-phase, half-wave, 60HZ, resistive or inductive load rating at 25°C, unless otherwise stated, for capacitive load, derate current by 20%)

	SYMBOL	GS 3A	GS 3B	GS 3D	GS 3G	GS 3J	GS 3K	GS 3M	units
Maximum Recurrent Peak Reverse Voltage	V <sub>rrm</sub>	50	100	200	400	600	800	1000	V
Maximum RMS Voltage	V <sub>rms</sub>	35	70	140	280	420	560	700	V
Maximum DC blocking Voltage	V <sub>d</sub>	50	100	200	400	600	800	1000	V
Maximum Average Forward Rectified Current 3/8"lead length at T <sub>L</sub> =75°C	I <sub>f(av)</sub>	3.0							A
Peak Forward Surge Current 8.3ms single half sine-wave superimposed on rated load	I <sub>fsm</sub>	100.0							A
Maximum Forward Voltage at rated Forward current	V <sub>f</sub>	1.1							V
Maximum DC Reverse Current at rated DC blocking voltage Ta =25°C Ta =125°C	I <sub>r</sub>	5.0 250							uA
Typical Reverse Recovery Time (Note 1)	T <sub>rr</sub>	2.3							us
Typical Junction Capacitance (Note 2)	C <sub>j</sub>	60.0							pF
Typical Thermal Resistance (Note 3)	R <sub>th(ja)</sub>	47.0							°C/W
	R <sub>th(jl)</sub>	13.0							
	R <sub>th(jc)</sub>	28.0							
Storage and Operating Temperature Range	T <sub>stg</sub>	-50 to +150							°C

- Note:
- Reverse Recovery Condition I<sub>f</sub> =0.5A, I<sub>r</sub> =1.0A, I<sub>rr</sub> =0.25A
  - Measured at 1.0 MHz and applied voltage of 4.0Vdc
  - Thermal Resistance from junction to ambient and from junction to lead mounted on 8×8mm copper pad area

AVERAGE FORWARD RECTIFIED CURRENT, AMPERES

**FIG. 1- FORWARD CURRENT DERATING CURVE**

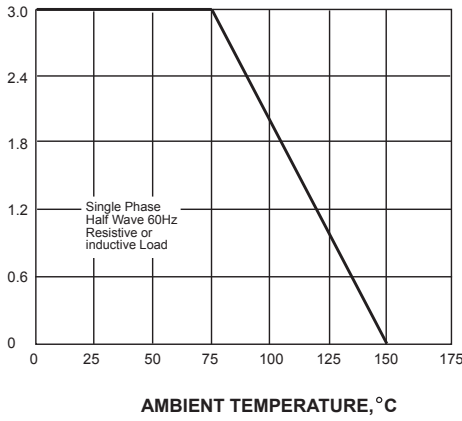

PEAK FORWARD SURGE CURRENT, AMPERES

**FIG. 2-MAXIMUM NON-REPETITIVE PEAK FORWARD SURGE CURRENT**

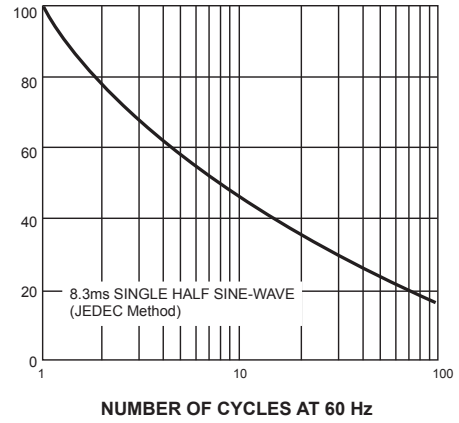

INSTANTANEOUS FORWARD CURRENT, AMPERES

**FIG. 3-TYPICAL INSTANTANEOUS FORWARD CHARACTERISTICS**

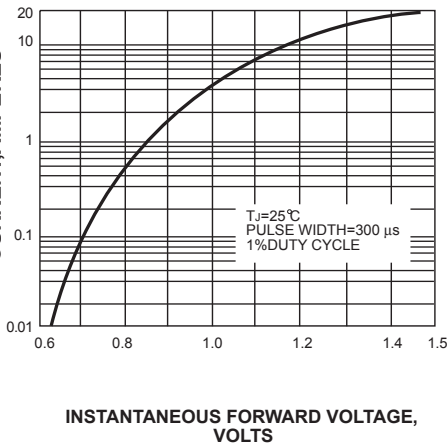

INSTANTANEOUS REVERSE CURRENT, MICROAMPERES

**FIG. 4-TYPICAL REVERSE CHARACTERISTICS**

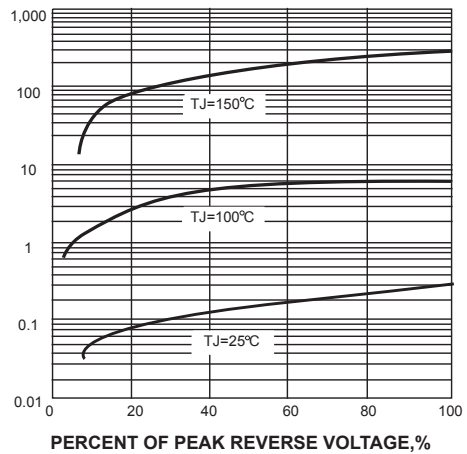

JUNCTION CAPACITANCE, pF

**FIG. 5-TYPICAL JUNCTION CAPACITANCE**

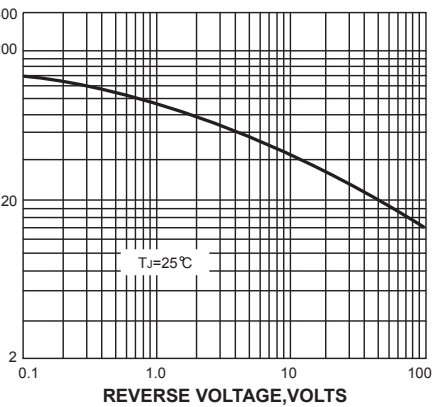

TRANSIENT THERMAL IMPEDANCE, °C/W

**FIG. 6-TYPICAL TRANSIENT THERMAL IMPEDANCE**

