

20V Dual N-Channel MOSFET

Description

The PM8205B uses advanced Trench technology and designs to provide excellent $R_{DS(ON)}$ with low gate charge. This device is suitable for use in PWM, load switching and general purpose applications.

Features

- 20V MOSFET Technology
- Very low on-resistance
- Super fast switching speed
- Cost-effective

Applications

- Charge protection for lithium batteries (only used for lithium battery protector)
- Drain internal connection, not external use.

The circuit is not applicable as follows:

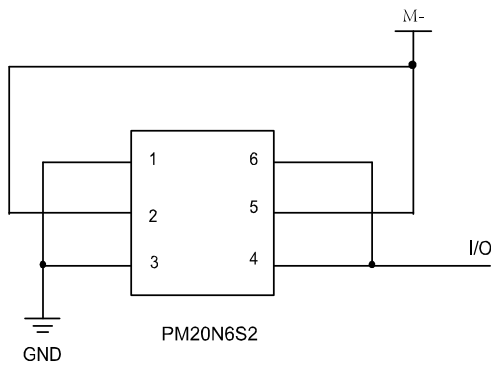

- Drain end elicited circuit, which can not be used
- Parallel G1/G2 do single MOS can not be used

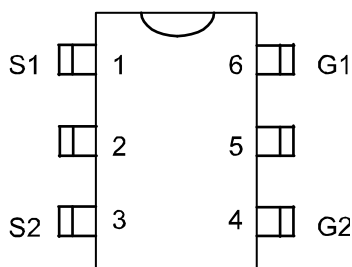

Top View

- D1/D2 Pin2 and Pin5 do not connect

Dimensions and Pin Configuration

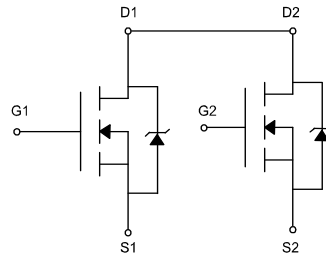

Circuit diagram

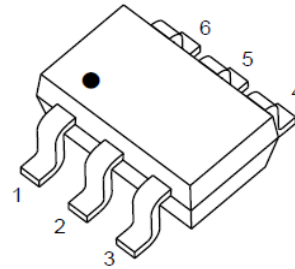

SOT-23-6

Marking Information

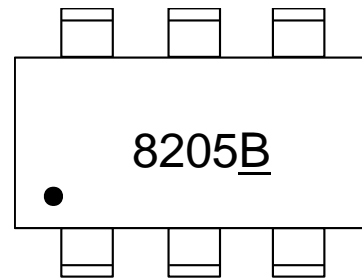

8205 = Device Marking Code

MOSFET Product Summary

V_{DSS}	$R_{DS(ON)}$ @ $V_{GS} = 4.5V$	$R_{DS(ON)}$ @ $V_{GS} = 2.5V$	I_D
20V	15m Ω	21m Ω	8A

Absolute Maximum Ratings (T_A=25°C unless otherwise noted)

Parameter	Symbol	Value	Unit
Drain-Source Voltage	V _{DS}	20	V
Gate-Source Voltage	V _{GS}	±8	V
Continuous Drain Current (V _{GS} =4.5V, @T _A =25°C)	I _D	8	A
Continuous Drain Current (V _{GS} =4.5V, @T _A =70°C)	I _D	6	A
Pulsed Drain Current	I _{DM}	20	A
Power Dissipation (t≤10s, @T _A =25°C)	P _D	1.5	W
Thermal Resistance from Junction to Ambient(t≤10s)	R _{θJA}	83	°C/W
Junction Temperature	T _J	150	°C
Storage Temperature	T _{STG}	-55~ +150	°C

Electrical Characteristics (T_A = 25°C unless otherwise noted)

Parameter	Symbol	Test Condition	Min.	Typ.	Max.	Unit
Static Characteristics						
Drain-source breakdown voltage	V _{(BR)DSS}	V _{GS} = 0V, I _D =250μA	19.5	20.5	-	V
Zero gate voltage drain current	I _{DSS}	V _{DS} =16V, V _{GS} = 0V	-	-	1	μA
Gate-body leakage current	I _{GSS}	V _{GS} =±6V, V _{DS} = 0V	-	-	±1	μA
Breakdown voltage temperature coefficient	ΔV _{DSS} /ΔT _j	T _A =25°C, I _D =1mA	-	0.03	-	V/°C
Gate threshold voltage	V _{GS(th)}	V _{DS} =V _{GS} , I _D =250μA	0.4	0.65	1.0	V
Drain-source on-resistance	R _{DS(ON)}	V _{GS} =4.5V, I _D = 6.0A	-	30	38	mΩ
		V _{GS} =3.8V, I _D = 3.0A	-	35	46	
		V _{GS} =2.5V, I _D = 3.0A	-	42	60	
Forward trans conductance	g _{FS}	V _{DS} =5V, I _D =4.5A	-	10	-	S
Diode forward voltage	V _{SD}	I _S =1.0A, V _{GS} =0V, T _j =25°C	-	0.72	1.2	V
Drain source continuous current	I _S	-	-	-	1.7	A

SOT 23-6 Package Outline Drawing

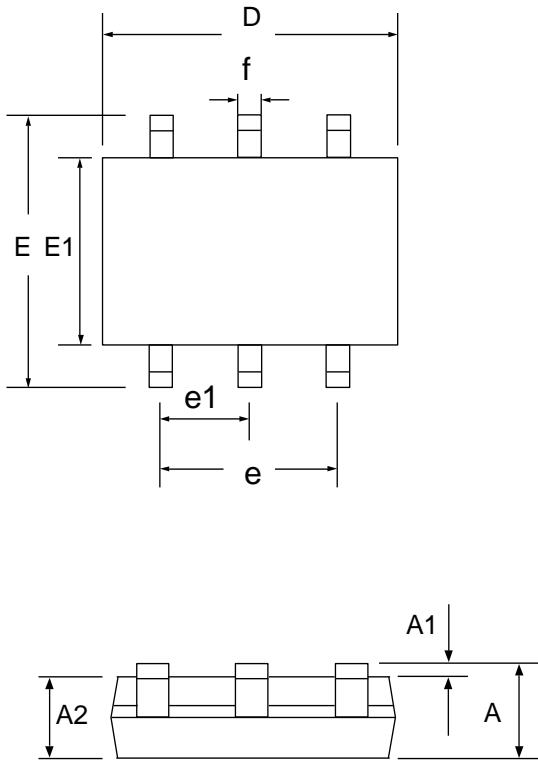

SYM	DIMENSIONS					
	MILLIMETERS			INCHES		
	MIN	NOM	MAX	MIN	NOM	MAX
A	0.90		1.45	0.035		0.057
A1	0.00		0.15	0.000		0.006
A2	0.90	1.15	1.30	0.035	0.045	0.051
D	2.80	2.90	3.10	0.110	0.114	0.122
E	2.80 BSC			0.110 BSC		
E1	1.50	1.60	1.75	0.060	0.063	0.069
e	1.90 BSC			0.075 BSC		
e1	0.95 BSC			0.037 BSC		
f	0.30		0.50	0.012		0.020

Suggested Land Pattern

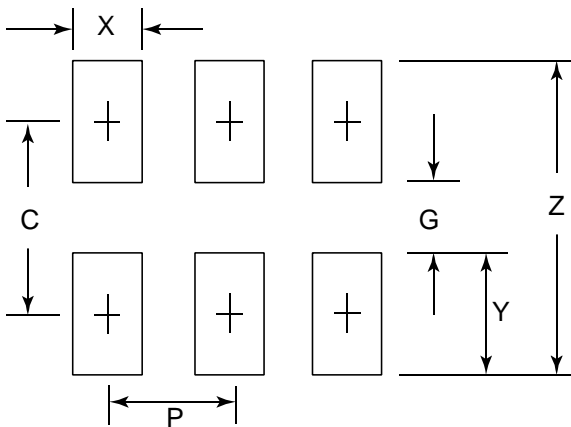

SYM	DIMENSIONS	
	MILLIMETERS	INCHES
C	2.50	0.098
G	1.40	0.055
P	0.95	0.037
X	0.60	0.024
Y	1.10	0.043
Z	3.60	0.141