

600W Transient Voltage Suppressor

Description

TVS diodes can be used in a wide range of applications which like consumer electronic products, automotive industries, munitions, telecommunications, aerospace industries, and intelligent control systems.

Features

- Glass passivated or planar junction
- Excellent clamping capability
- Repetition rate (duty cycle): 0.01%
- Low profile package and low inductance
- 600W Peak Pulse power capability at 10×1000μs waveform.
- Fast response time: typically less than 1.0ps from 0V to V_{BRmin} .
- High temperature soldering: 260°C/10s at terminals.
- Plastic package has Underwriters Laboratory Flammability 94V-0.
- For surface mounted applications in order to optimize board space.

Dimensions & Symbol (Unit: mm Max)

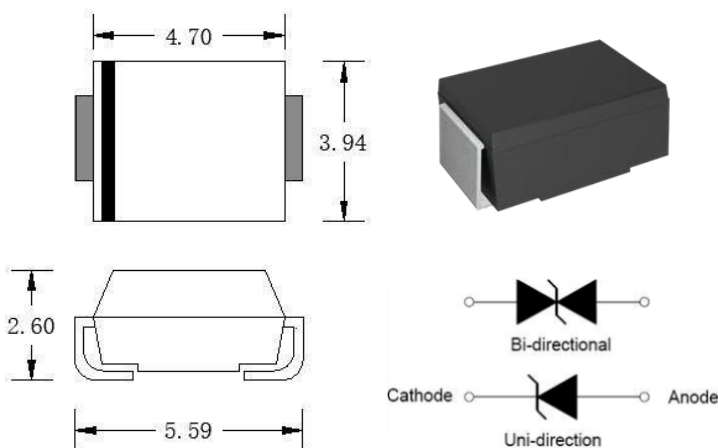

Mechanical Characteristics

Package: SMB/DO-214AA

- Case Material: “Green” MoldingCompound.
- UL Flammability Classification Rating 94V-0
- Polarity: Color band denotes cathode except bi-directional models
- Standard Packaging: 12mm tape (EIA STD RS-481)
- Weight: 0.10g
- Terminal Connections: See Diagram Below
- Marking Information: See Below

Applications

- I/O Interface.
- AC/DC Power supply
- Low frequency signal transmission line (RS232, RS485, etc.)

Marking Information

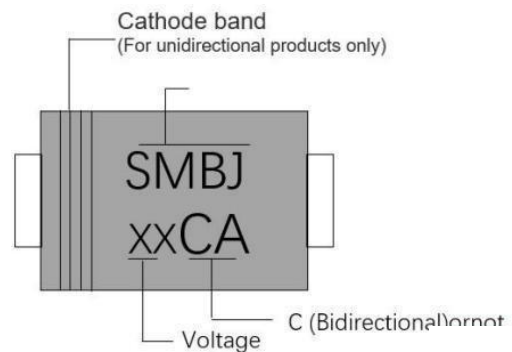

Ordering information

Out line	Reel (pcs)	Per carton (pcs)	Reel diameters (mm)
Taping	3K	48K	330

Electrical Characteristics (T =25°C)

Part Number		Marking		V _R	I _R @V _R	V _{BR} @I _T		I _T	V _C @I _{PP}	I _{PP} ^①
Uni-Polar	Bi-Polar	Uni	Bi	V	μA	min(V)	max(V)	mA	max(V)	A
SMBJ5.0A	SMBJ5.0CA	SMBJ5.0A	SMBJ5.0CA	5.0	800	6.40	7.00	10	9.2	65.2
SMBJ6.0A	SMBJ6.0CA	SMBJ6.0A	SMBJ6.0CA	6.0	800	6.67	7.37	10	10.3	58.3
SMBJ6.5A	SMBJ6.5CA	SMBJ6.5A	SMBJ6.5CA	6.5	500	7.22	7.98	10	11.2	53.6
SMBJ7.0A	SMBJ7.0CA	SMBJ7.0A	SMBJ7.0CA	7.0	200	7.78	8.60	10	12.0	50.0
SMBJ7.5A	SMBJ7.5CA	SMBJ7.5A	SMBJ7.5CA	7.5	100	8.33	9.21	1	12.9	46.5
SMBJ8.0A	SMBJ8.0CA	SMBJ8.0A	SMBJ8.0CA	8.0	50	8.89	9.83	1	13.6	44.1
SMBJ8.5A	SMBJ8.5CA	SMBJ8.5A	SMBJ8.5CA	8.5	20	9.44	10.40	1	14.4	41.7
SMBJ9.0A	SMBJ9.0CA	SMBJ9.0A	SMBJ9.0CA	9.0	10	10.00	11.10	1	15.4	39.0
SMBJ10A	SMBJ10CA	SMBJ10A	SMBJ10CA	10	5	11.10	12.30	1	17.0	35.3
SMBJ11A	SMBJ11CA	SMBJ11A	SMBJ11CA	11	1	12.20	13.50	1	18.2	33.0
SMBJ12A	SMBJ12CA	SMBJ12A	SMBJ12CA	12	1	13.30	14.70	1	19.9	30.2
SMBJ13A	SMBJ13CA	SMBJ13A	SMBJ13CA	13	1	14.40	15.90	1	21.5	27.9
SMBJ14A	SMBJ14CA	SMBJ14A	SMBJ14CA	14	1	15.60	17.20	1	23.2	25.9
SMBJ15A	SMBJ15CA	SMBJ15A	SMBJ15CA	15	1	16.70	18.50	1	24.4	24.6
SMBJ16A	SMBJ16CA	SMBJ16A	SMBJ16CA	16	1	17.80	19.70	1	26.0	23.1
SMBJ17A	SMBJ17CA	SMBJ17A	SMBJ17CA	17	1	18.90	20.90	1	27.6	21.8
SMBJ18A	SMBJ18CA	SMBJ18A	SMBJ18CA	18	1	20.00	22.10	1	29.2	20.6
SMBJ20A	SMBJ20CA	SMBJ20A	SMBJ20CA	20	1	22.20	24.50	1	32.4	18.6
SMBJ22A	SMBJ22CA	SMBJ22A	SMBJ22CA	22	1	24.40	26.90	1	35.5	16.9
SMBJ24A	SMBJ24CA	SMBJ24A	SMBJ24CA	24	1	26.70	29.50	1	38.9	15.4
SMBJ26A	SMBJ26CA	SMBJ26A	SMBJ26CA	26	1	28.90	31.90	1	42.1	14.3
SMBJ28A	SMBJ28CA	SMBJ28A	SMBJ28CA	28	1	31.10	34.40	1	45.4	13.2
SMBJ30A	SMBJ30CA	SMBJ30A	SMBJ30CA	30	1	33.30	36.80	1	48.4	12.4
SMBJ33A	SMBJ33CA	SMBJ33A	SMBJ33CA	33	1	36.70	40.60	1	53.3	11.3
SMBJ36A	SMBJ36CA	SMBJ36A	SMBJ36CA	36	1	40.00	44.20	1	58.1	10.4
SMBJ40A	SMBJ40CA	SMBJ40A	SMBJ40CA	40	1	44.40	49.10	1	64.5	9.3
SMBJ43A	SMBJ43CA	SMBJ43A	SMBJ43CA	43	1	47.80	52.80	1	69.4	8.7
SMBJ45A	SMBJ45CA	SMBJ45A	SMBJ45CA	45	1	50.00	55.30	1	72.7	8.3
SMBJ48A	SMBJ48CA	SMBJ48A	SMBJ48CA	48	1	53.30	58.90	1	77.4	7.8
SMBJ51A	SMBJ51CA	SMBJ51A	SMBJ51CA	51	1	56.70	62.70	1	82.4	7.3

Electrical Characteristics (T =25°C)

Part Number		Marking		V _R	I _R @V _R	V _{BR} @I _T		I _T	V _C @I _{PP}	I _{PP} ^①
Uni-Polar	Bi-Polar	Uni	Bi	V	μA	min(V)	max(V)	mA	max(V)	A
SMBJ54A	SMBJ54CA	SMBJ54A	SMBJ54CA	54	1	60.00	66.30	1	87.1	6.9
SMBJ58A	SMBJ58CA	SMBJ58A	SMBJ58CA	58	1	64.40	71.20	1	93.6	6.4
SMBJ60A	SMBJ60CA	SMBJ60A	SMBJ60CA	60	1	66.70	73.70	1	96.8	6.2
SMBJ64A	SMBJ64CA	SMBJ64A	SMBJ64CA	64	1	71.10	78.60	1	103.0	5.8
SMBJ70A	SMBJ70CA	SMBJ70A	SMBJ70CA	70	1	77.80	86.00	1	113.0	5.3
SMBJ75A	SMBJ75CA	SMBJ75A	SMBJ75CA	75	1	83.30	92.10	1	121.0	5.0
SMBJ78A	SMBJ78CA	SMBJ78A	SMBJ78CA	78	1	86.70	95.80	1	126.0	4.8
SMBJ85A	SMBJ85CA	SMBJ85A	SMBJ85CA	85	1	94.40	104.0	1	137.0	4.4
SMBJ90A	SMBJ90CA	SMBJ90A	SMBJ90CA	90	1	100.0	111.0	1	146.0	4.1
SMBJ100A	SMBJ100CA	SMBJ100A	SMBJ100CA	100	1	111.0	123.0	1	162.0	3.7
SMBJ110A	SMBJ110CA	SMBJ110A	SMBJ110CA	110	1	122.0	135.0	1	177.0	3.4
SMBJ120A	SMBJ120CA	SMBJ120A	SMBJ120CA	120	1	133.0	147.0	1	193.0	3.1
SMBJ130A	SMBJ130CA	SMBJ130A	SMBJ130CA	130	1	144.0	159.0	1	209.0	2.9
SMBJ150A	SMBJ150CA	SMBJ150A	SMBJ150CA	150	1	167.0	185.0	1	243.0	2.5
SMBJ160A	SMBJ160CA	SMBJ160A	SMBJ160CA	160	1	178.0	197.0	1	259.0	2.3
SMBJ170A	SMBJ170CA	SMBJ170A	SMBJ170CA	170	1	189.0	209.0	1	275.0	2.2
SMBJ180A	SMBJ180CA	SMBJ180A	SMBJ180CA	180	1	201.0	222.0	1	292.0	2.1
SMBJ190A	SMBJ190CA	SMBJ190A	SMBJ190CA	190	1	211.0	234.0	1	307.0	2.0
SMBJ200A	SMBJ200CA	SMBJ200A	SMBJ200CA	200	1	224.0	247.0	1	324.0	1.9
SMBJ210A	SMBJ210CA	SMBJ210A	SMBJ210CA	210	1	233.0	258.0	1	337.0	1.8
SMBJ220A	SMBJ220CA	SMBJ220A	SMBJ220CA	220	1	246.0	272.0	1	356.0	1.7
SMBJ250A	SMBJ250CA	SMBJ250A	SMBJ250CA	250	1	279.0	309.0	1	405.0	1.5
SMBJ300A	SMBJ300CA	SMBJ300A	SMBJ300CA	300	1	335.0	371.0	1	486.0	1.3
SMBJ350A	SMBJ350CA	SMBJ350A	SMBJ350CA	350	1	391.0	432.0	1	567.0	1.1
SMBJ400A	SMBJ400CA	SMBJ400A	SMBJ400CA	400	1	447.0	494.0	1	648.0	0.9
SMBJ440A	SMBJ440CA	SMBJ440A	SMBJ440CA	440	1	492.0	543.0	1	713.0	0.8

① Surge waveform: 10/1000μs

V_R : Stand-off Voltage -- Maximum voltage that can be applied

V_{BR}: Breakdown Voltage

V_C: Clamping Voltage -- Peak voltage measured across the suppressor at a specified I_{pp}

I_R: Reverse Leakage Current

Part Number Code

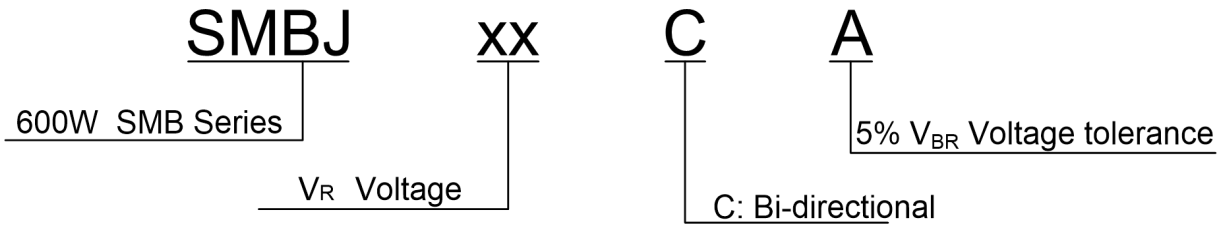

Absolute Maximum Ratings($T = 25^{\circ}C$, RH=45%-75%, unless otherwise noted)

Parameter	Symbol	Value	Unit
Storage temperature range	T_{stg}	-55 to +150	$^{\circ}C$
Operating junction temperature range	T_j	-55 to +150	$^{\circ}C$
Steady state power dissipation at $T_L=75^{\circ}C$	$P_{M(AV)}$	5.0	W
Peak pulse power dissipation on 10/1000 μ s waveform	P_{PP}	600	W
Maximum Instantaneous Forward Voltage at 50A for Unidirectional	V_F	5.0	V

Ratings And V-I Characteristics curves ($T_A=25^{\circ}C$, unless otherwise noted)

FIG.1:V- I curve characteristics (Uni-directional)

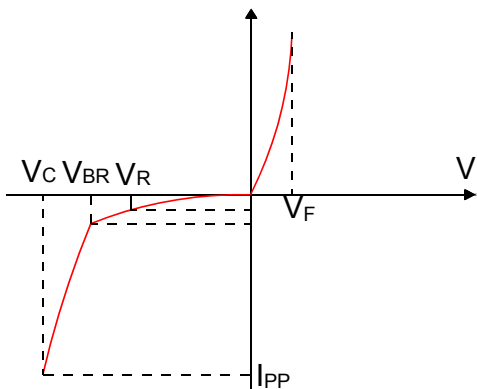
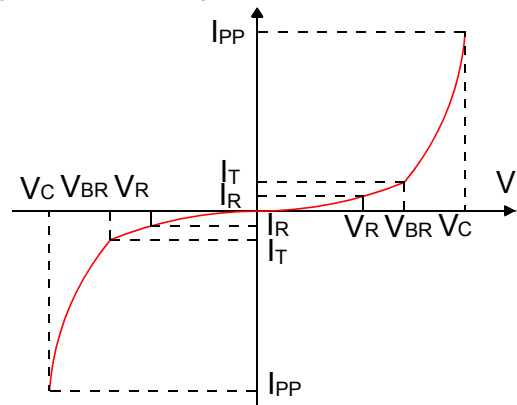

FIG.2:V- I curve characteristics (Bi-directional)



Typical Characteristics

Figure 1: Peak Pulse Power Rating Curve

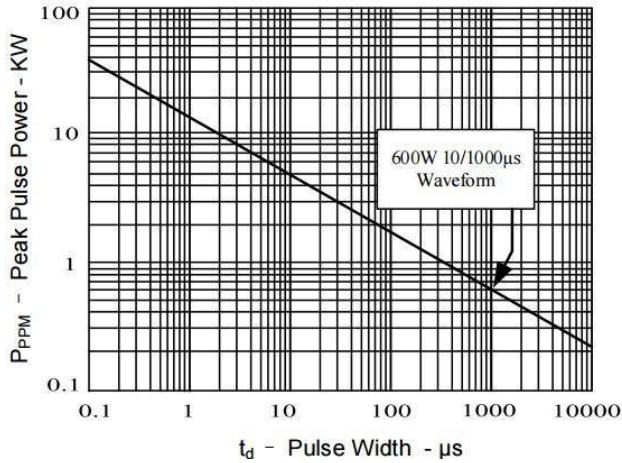

Figure 2: Pulse Derating Curve

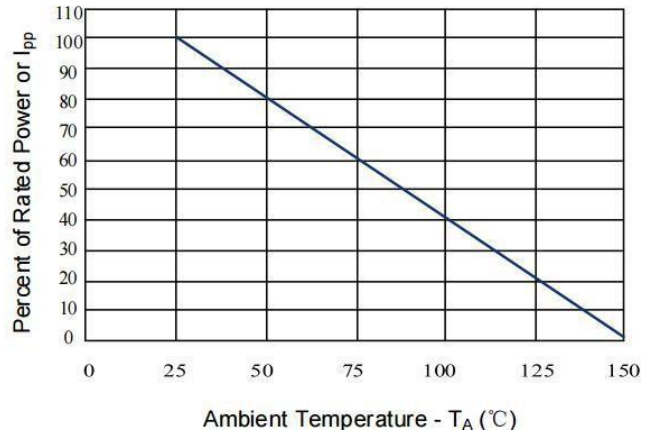

Figure 3: Pulse Waveform

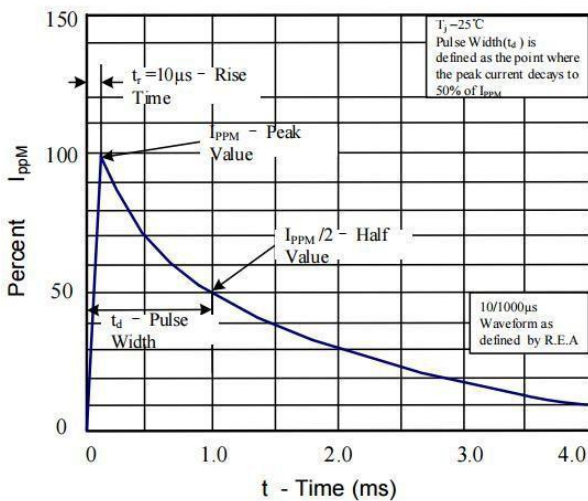

Figure 4: Typical Junction Capacitance

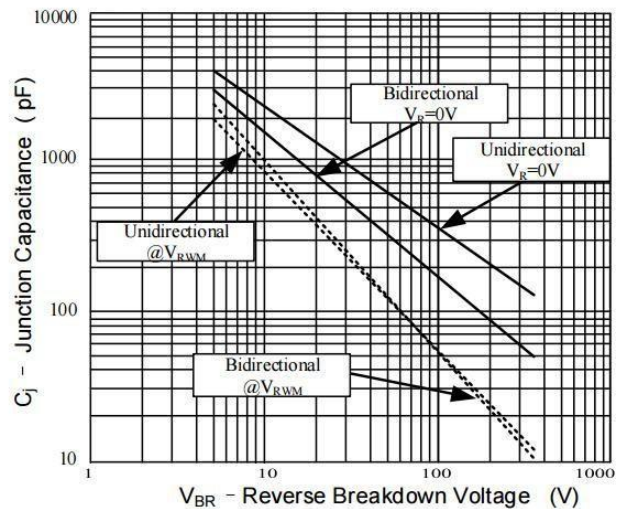

Figure 5: Steady State Power Dissipation Derating Curve

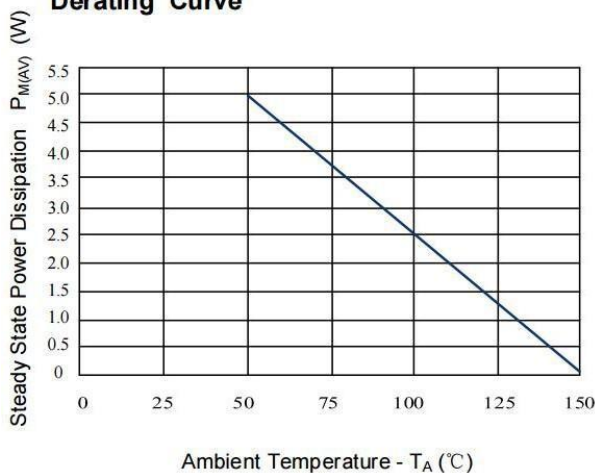
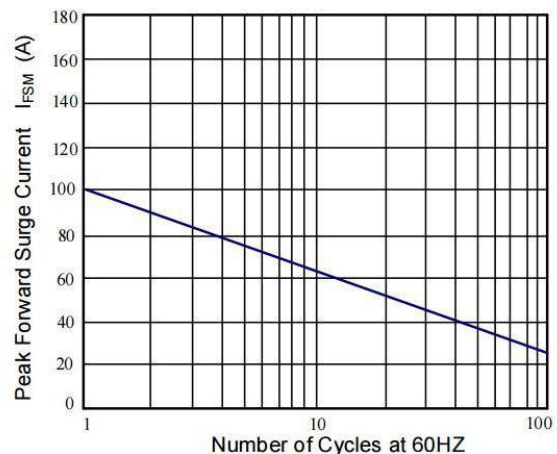
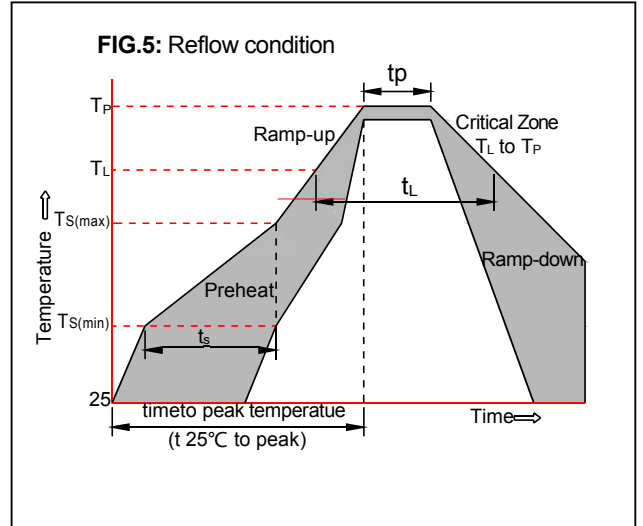

Figure 6: Maximum Non-Repetitive Forward Surge Current Only Unidirectional



Soldering Parameters

Reflow Condition		Pb-Free assembly (see as below)
Pre Heat	-Temperature Min ($T_{s(min)}$)	+150°C
	-Temperature Max($T_{s(max)}$)	+200°C
	-Time (Min to Max) (ts)	60-180 secs.
Average ramp up rate (Liquid us Temp (T_L) to peak)		3°C/sec. Max
$T_{s(max)}$ to T_L - Ramp-up Rate		3°C/sec. Max
Reflow	-Temperature(T_L)(Liquid us)	+217°C
	-Temperature(t_L)	60-150 secs.
Peak Temp (T_p)		+260(+0/-5)°C
Time within 5°C of actual Peak Temp (t_p)		30 secs. Max
Ramp-down Rate		6°C/sec. Max
Time 25°C to Peak Temp (T_p)		8 min. Max
Do not exceed		+260°C



Package Mechanical data

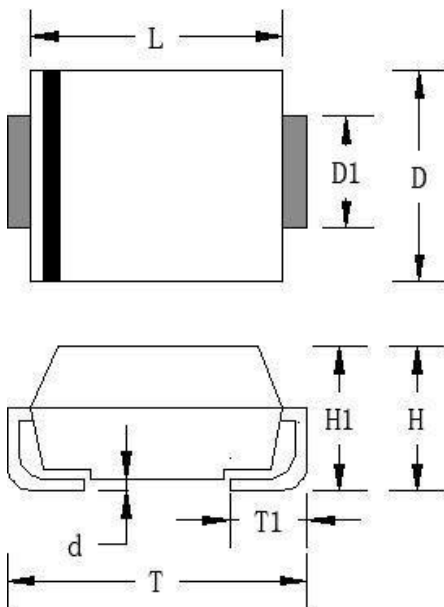

Ref.(mm)	Millimeters	
	Min.	Max.
D	3.40	3.94
D1	1.90	2.10
L	4.22	4.70
T	5.21	5.59
T1	0.90	1.42
d	0	0.23
H	1.95	2.6
H1	2.0	2.34

Tape & Reel specification - SMB

Symbol	Spec		
W	12±0.2		
E	1.75±0.1		
F	5.5±0.05		
D0	1.55±0.05		
D1	1.5±0.1		
P0	4.0±0.1		
P1	8.0±0.1		
P2	2.0±0.05		
T	0.23±0.02		
A0	2.79±0.1		
B0	5.74±0.1		
K0	2.46±0.1		
T1	0.05 以上		
D5	Ø330±2.0		13" Reel
D6	Ø13.5±0.5		
H	2.5±1.0		
W2	16±2.0		
Quantity:3000PCS			
D2	Ø178.0±2.0	7" Reel	
D3	Ø50Min.		
D4	Ø13.0±0.5		
W1	16.0±2.0		
Quantity:500PCS			