

400W Transient Voltage Suppressor

Description

TVS diodes can be used in a wide range of applications which like consumer electronic products, automotive industries, munitions, telecommunications, aerospace industries, and intelligent control systems.

Features

- Glass passivated or planar junction
- Excellent clamping capability
- Repetition rate (duty cycle): 0.01%
- Low profile package and low inductance
- 400W Peak Pulse power capability at 10×1000µs waveform.
- Fast response time: typically less than 1.0ps from 0V to V_{BR} min.
- High temperature soldering: 260°C/10s at terminals.
- Plastic package has Underwriters Laboratory Flammability 94V-0.
- For surface mounted applications in order to optimize board space.

Dimensions & Symbol (Unit: mm Max)

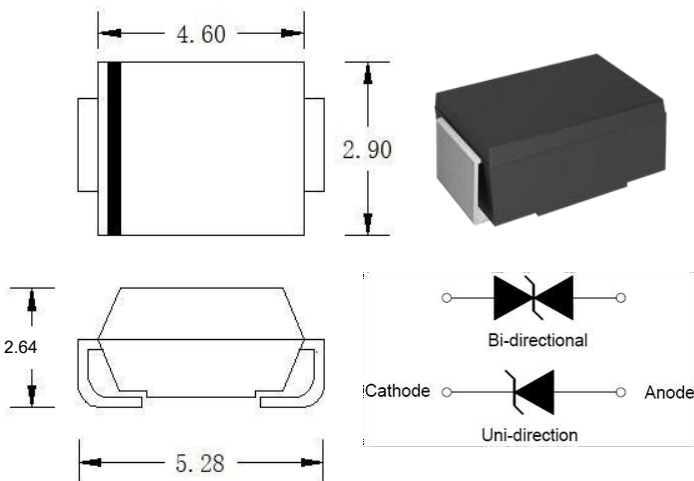

Mechanical Characteristics

Package: SMA/DO-214AC

- Case Material: “Green” MoldingCompound.
- UL Flammability Classification Rating 94V-0
- Polarity: Color band denotes cathode except bi-directional models
- Standard Packaging: 12mm tape (EIA STD RS-481)
- Weight: 0.07g
- Terminal Connections: See Diagram Below
- Marking Information: See Below

Applications

- I/O Interface.
- AC/DC Power supply
- Low frequency signal transmission line (RS232, RS485, etc.)

Marking Information

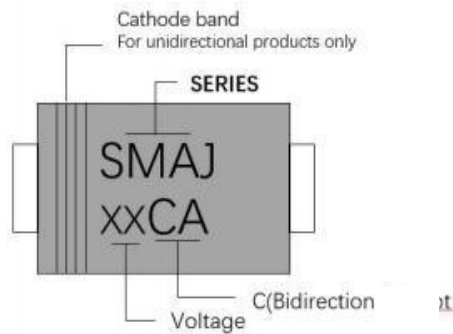

Ordering Information

Out line	Reel (pcs)	Per carton (pcs)	Reel diameters (mm)
Taping	5K	80K	330

Electrical Characteristics (T =25°C)

Part Number		Marking		V _R	I _R @V _R	V _{BR} @I _T		I _T	V _C @I _{PP}	I _{PP} [®]
Uni-Polar	Bi-Polar	Uni	Bi	V	μA	min(V)	max(V)	mA	max(V)	A
SMAJ5.0A	SMAJ5.0CA	SMAJ5.0A	SMAJ5.0CA	5.0	800	6.40	7.00	10	9.2	43.5
SMAJ6.0A	SMAJ6.0CA	SMAJ6.0A	SMAJ6.0CA	6.0	800	6.67	7.37	10	10.3	38.8
SMAJ6.5A	SMAJ6.5CA	SMAJ6.5A	SMAJ6.5CA	6.5	500	7.22	7.98	10	11.2	35.7
SMAJ7.0A	SMAJ7.0CA	SMAJ7.0A	SMAJ7.0CA	7.0	200	7.78	8.60	10	12.0	33.3
SMAJ7.5A	SMAJ7.5CA	SMAJ7.5A	SMAJ7.5CA	7.5	100	8.33	9.21	1	12.9	31.0
SMAJ8.0A	SMAJ8.0CA	SMAJ8.0A	SMAJ8.0CA	8.0	50	8.89	9.83	1	13.6	29.4
SMAJ8.5A	SMAJ8.5CA	SMAJ8.5A	SMAJ8.5CA	8.5	20	9.44	10.40	1	14.4	27.8
SMAJ9.0A	SMAJ9.0CA	SMAJ9.0A	SMAJ9.0CA	9.0	10	10.00	11.10	1	15.4	26.0
SMAJ10A	SMAJ10CA	SMAJ10A	SMAJ10CA	10.0	5	11.10	12.30	1	17.0	23.5
SMAJ11A	SMAJ11CA	SMAJ11A	SMAJ11CA	11.0	1	12.20	13.50	1	18.2	22.0
SMAJ12A	SMAJ12CA	SMAJ12A	SMAJ12CA	12.0	1	13.30	14.70	1	19.9	20.1
SMAJ13A	SMAJ13CA	SMAJ13A	SMAJ13CA	13.0	1	14.40	15.90	1	21.5	18.6
SMAJ14A	SMAJ14CA	SMAJ14A	SMAJ14CA	14.0	1	15.60	17.20	1	23.2	17.3
SMAJ15A	SMAJ15CA	SMAJ15A	SMAJ15CA	15.0	1	16.70	18.50	1	24.4	16.4
SMAJ16A	SMAJ16CA	SMAJ16A	SMAJ16CA	16.0	1	17.80	19.70	1	26.0	15.4
SMAJ17A	SMAJ17CA	SMAJ17A	SMAJ17CA	17.0	1	18.90	20.90	1	27.6	14.5
SMAJ18A	SMAJ18CA	SMAJ18A	SMAJ18CA	18.0	1	20.00	22.10	1	29.2	13.7
SMAJ20A	SMAJ20CA	SMAJ20A	SMAJ20CA	20.0	1	22.20	24.50	1	32.4	12.4
SMAJ22A	SMAJ22CA	SMAJ22A	SMAJ22CA	22.0	1	24.40	26.90	1	35.5	11.3
SMAJ24A	SMAJ24CA	SMAJ24A	SMAJ24CA	24.0	1	26.70	29.50	1	38.9	10.3
SMAJ26A	SMAJ26CA	SMAJ26A	SMAJ26CA	26.0	1	28.90	31.90	1	42.1	9.5
SMAJ28A	SMAJ28CA	SMAJ28A	SMAJ28CA	28.0	1	31.10	34.40	1	45.4	8.8
SMAJ30A	SMAJ30CA	SMAJ30A	SMAJ30CA	30.0	1	33.30	36.80	1	48.4	8.3
SMAJ33A	SMAJ33CA	SMAJ33A	SMAJ33CA	33.0	1	36.70	40.60	1	53.3	7.5
SMAJ36A	SMAJ36CA	SMAJ36A	SMAJ36CA	36.0	1	40.00	44.20	1	58.1	6.9
SMAJ40A	SMAJ40CA	SMAJ40A	SMAJ40CA	40.0	1	44.40	49.10	1	64.5	6.2
SMAJ43A	SMAJ43CA	SMAJ43A	SMAJ43CA	43.0	1	47.80	52.80	1	69.4	5.8
SMAJ45A	SMAJ45CA	SMAJ45A	SMAJ45CA	45.0	1	50.00	55.30	1	72.7	5.5
SMAJ48A	SMAJ48CA	SMAJ48A	SMAJ48CA	48.0	1	53.30	58.90	1	77.4	5.2
SMAJ51A	SMAJ51CA	SMAJ51A	SMAJ51CA	51.0	1	56.70	62.70	1	82.4	4.9

Electrical Characteristics (T =25°C)

Part Number		Marking		V _R	I _R @V _R	V _{BR} @I _T		I _T	V _C @I _{PP}	I _{PP} ^①
Uni-Polar	Bi-Polar	Uni	Bi	V	μA	min(V)	max(V)	mA	max(V)	A
SMAJ54A	SMAJ54CA	SMAJ54A	SMAJ54CA	54.0	1	60.00	66.30	1	87.1	4.6
SMAJ58A	SMAJ58CA	SMAJ58A	SMAJ58CA	58.0	1	64.40	71.20	1	93.6	4.3
SMAJ60A	SMAJ60CA	SMAJ60A	SMAJ60CA	60.0	1	66.70	73.70	1	96.8	4.1
SMAJ64A	SMAJ64CA	SMAJ64A	SMAJ64CA	64.0	1	71.10	78.60	1	103.0	3.9
SMAJ70A	SMAJ70CA	SMAJ70A	SMAJ70CA	70.0	1	77.80	86.00	1	113.0	3.6
SMAJ75A	SMAJ75CA	SMAJ75A	SMAJ75CA	75.0	1	83.30	92.10	1	121.0	3.3
SMAJ78A	SMAJ78CA	SMAJ78A	SMAJ78CA	78.0	1	86.70	95.80	1	126.0	3.2
SMAJ85A	SMAJ85CA	SMAJ85A	SMAJ85CA	85.0	1	94.40	104.0	1	137.0	2.9
SMAJ90A	SMAJ90CA	SMAJ90A	SMAJ90CA	90.0	1	100.0	111.0	1	146.0	2.8
SMAJ100A	SMAJ100CA	SMAJ100A	SMAJ100CA	100.0	1	100.0	111.0	1	162.0	2.5
SMAJ110A	SMAJ110CA	SMAJ110A	SMAJ110CA	110.0	1	111.0	123.0	1	177.0	2.3
SMAJ120A	SMAJ120CA	SMAJ120A	SMAJ120CA	120.0	1	122.0	135.0	1	193.0	2.1
SMAJ130A	SMAJ130CA	SMAJ130A	SMAJ130CA	130.0	1	133.0	147.0	1	209.0	1.9
SMAJ150A	SMAJ150CA	SMAJ150A	SMAJ150CA	150.0	1	144.0	159.0	1	243.0	1.7
SMAJ160A	SMAJ160CA	SMAJ160A	SMAJ160CA	160.0	1	167.0	185.0	1	259.0	1.6
SMAJ170A	SMAJ170CA	SMAJ170A	SMAJ170CA	170.0	1	178.0	197.0	1	275.0	1.5
SMAJ180A	SMAJ180CA	SMAJ180A	SMAJ180CA	180.0	1	189.0	209.0	1	292.0	1.4
SMAJ200A	SMAJ200CA	SMAJ200A	SMAJ200CA	200.0	1	201.0	222.0	1	324.0	1.3
SMAJ220A	SMAJ220CA	SMAJ220A	SMAJ220CA	220.0	1	211.0	234.0	1	356.0	1.1
SMAJ250A	SMAJ250CA	SMAJ250A	SMAJ250CA	250.0	1	224.0	247.0	1	405.0	1.0
SMAJ300A	SMAJ300CA	SMAJ300A	SMAJ300CA	300.0	1	233.0	258.0	1	486.0	0.8
SMAJ350A	SMAJ350CA	SMAJ350A	SMAJ350CA	350.0	1	391.0	432.0	1	567.0	0.7
SMAJ400A	SMAJ400CA	SMAJ400A	SMAJ400CA	400.0	1	447.0	494.0	1	648.0	0.6
SMAJ440A	SMAJ440CA	SMAJ440A	SMAJ440CA	440.0	1	492.0	543.0	1	713.0	0.6

① Surge waveform: 10/1000μs

V_R : Stand-off Voltage -- Maximum voltage that can be applied

V_{BR}: Breakdown Voltage

V_C: Clamping Voltage -- Peak voltage measured across the suppressor at a specified I_{pp}

I_R: Reverse Leakage Current

Part Number Code

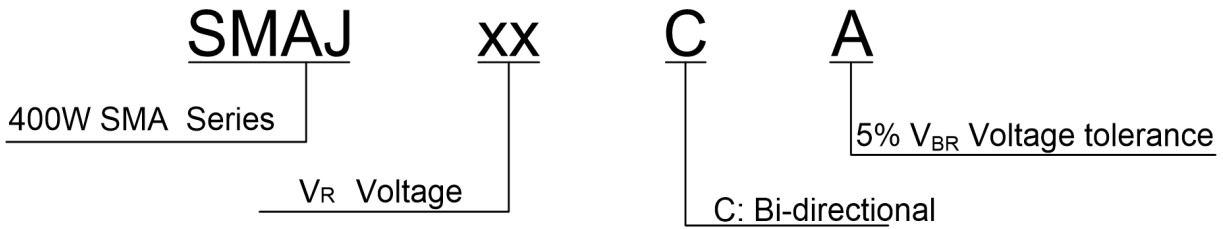

Absolute Maximum Ratings($T = 25^{\circ}C$, RH=45%-75%, unless otherwise noted)

Parameter	Symbol	Value	Unit
Storage temperature range	T_{stg}	-55 to +150	$^{\circ}C$
Operating junction temperature range	T_j	-55 to +150	$^{\circ}C$
Steady state power dissipation at $T_L=75^{\circ}C$	$P_{M(AV)}$	3.3	W
Peak pulse power dissipation on 10/1000 μs waveform	P_{PP}	400	W
Maximum Instantaneous Forward Voltage at 30A for Unidirectional	V_F	5.0	V

Ratings And V-I Characteristics Curves ($T = 25^{\circ}C$, unless otherwise noted)

FIG.1:V- I curve characteristics (Uni-directional)

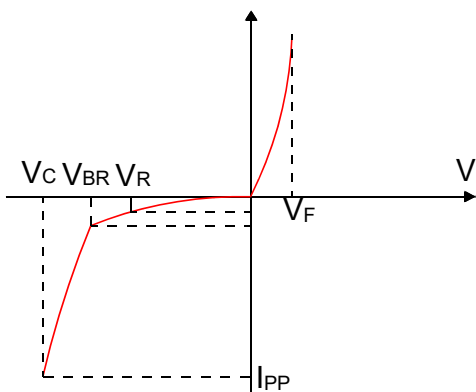
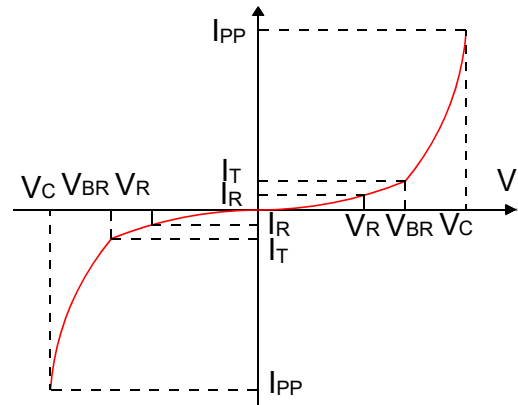

FIG.2:V- I curve characteristics (Bi-directional)



Typical Characteristics

Figure 1: Peak Pulse Power Rating Curve

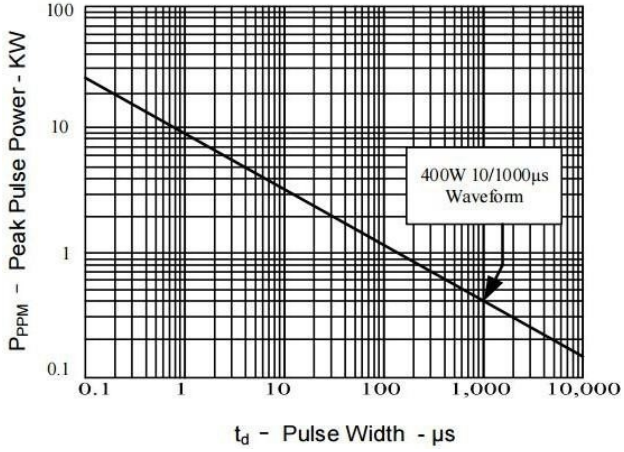

Figure 2: Pulse Derating Curve

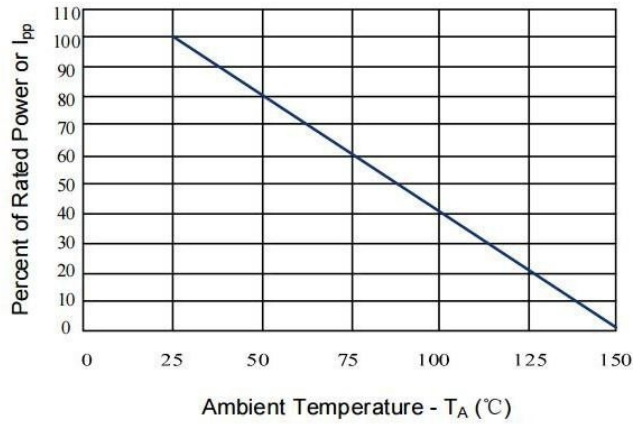

Figure 3: Pulse Waveform

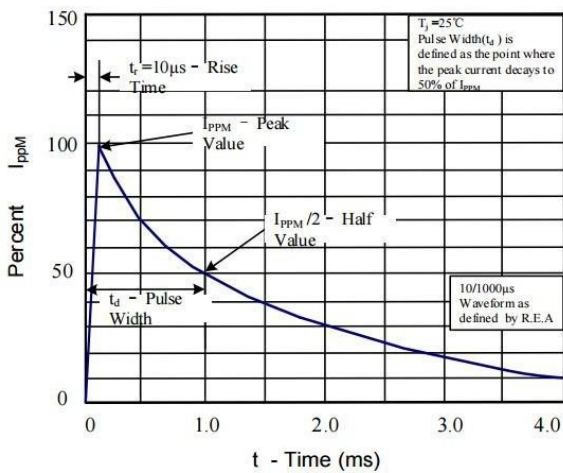

Figure 4: Typical Junction Capacitance

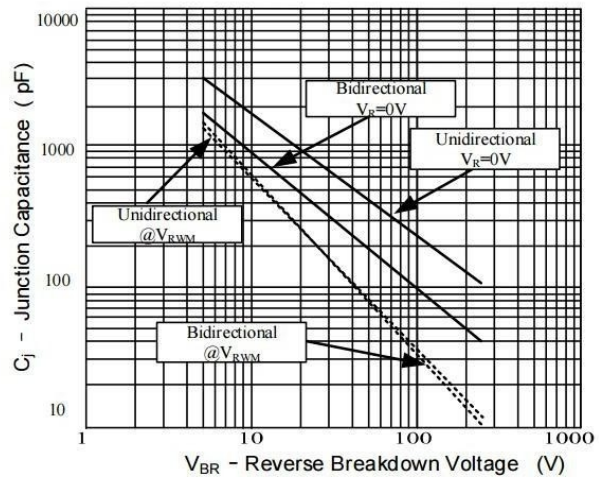

Figure 5: Steady State Power Dissipation Derating Curve

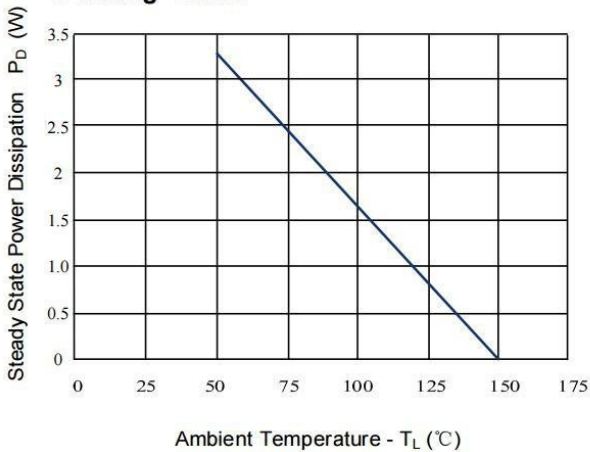
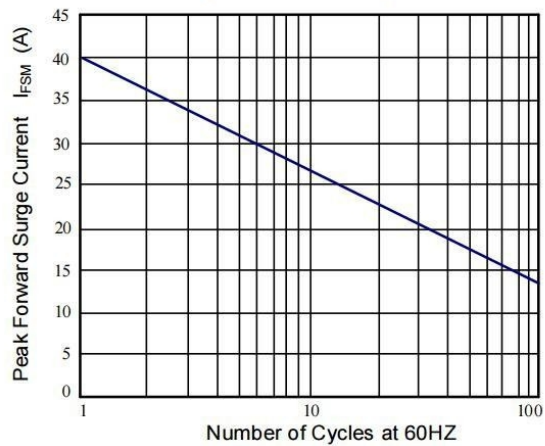
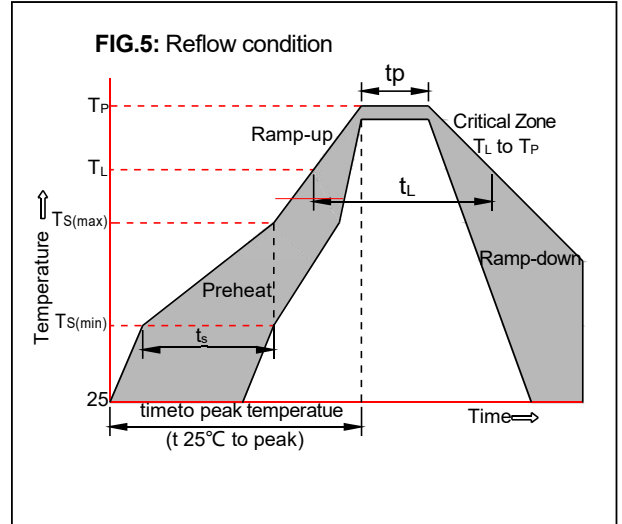

Figure 6: Maximum Non-Repetitive Forward Surge Current Only Unidirectional



Soldering Parameters

Reflow Condition		Pb-Free assembly (see as below)
Pre Heat	-Temperature Min ($T_{s(min)}$)	+150°C
	-Temperature Max ($T_{s(max)}$)	+200°C
	-Time (Min to Max) (ts)	60-180 secs.
Average ramp up rate (Liquid us Temp (T_L) to peak)		3°C/sec. Max
$T_{s(max)}$ to T_L - Ramp-up Rate		3°C/sec. Max
Reflow	-Temperature (T_L) (Liquid us)	+217°C
	-Temperature (t_L)	60-150 secs.
Peak Temp (T_P)		+260(+0/-5)°C
Time within 5°C of actual Peak Temp (t_p)		30 secs. Max
Ramp-down Rate		6°C/sec. Max
Time 25°C to Peak Temp (T_P)		8 min. Max
Do not exceed		+260°C



Package Mechanical Data

Ref.(mm)	Millimeters	
	Min.	Max.
D	2.50	2.79
D1	1.20	1.70
L	3.99	4.50
T	4.93	5.28
T1	0.76	1.52
d	0	0.203
H	1.98	2.4
H1	1.98	2.2

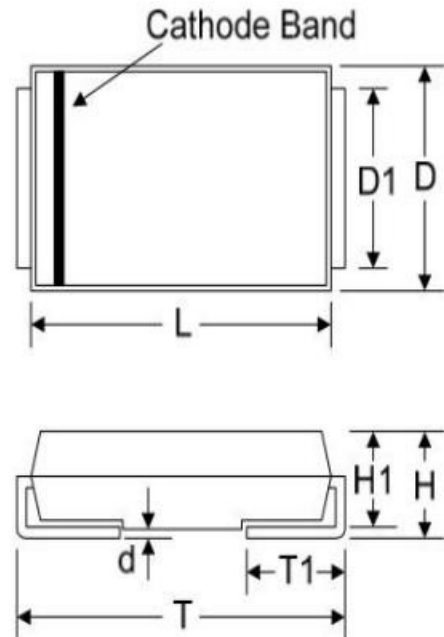

Tape & Reel Specification - SMA

Ref.	Dimensions	
	Millimeters	Inches
A	2.79 ± 0.3	0.110 ± 0.012
B	5.33 ± 0.3	0.210 ± 0.012
d	1.5 ± 0.1	0.059 ± 0.004
D	330.0	13.0
D2	13 ± 1	0.512 ± 0.039
E	1.5 ± 0.2	0.059 ± 0.008
F	5.65 ± 0.2	0.222 ± 0.008
P	4.0 ± 0.2	0.157 ± 0.008
P0	4.0 ± 0.2	0.157 ± 0.008
P1	2.0 ± 0.2	0.079 ± 0.008
W	12.0 ± 0.2	0.472 ± 0.008
W1	16.8 ± 2.0	0.661 ± 0.079

