

1-Line Uni-directional TVS Diode

Description

The PESDU4831P6 is an uni-directional TVS diode, to provide fast response time and low ESD clamping voltage, making this device an ideal solution for protecting voltage sensitive data and power line. The PESDU4831P6 complies with the IEC 61000-4-2 (ESD) with $\pm 30\text{kV}$ air and $\pm 30\text{kV}$ contact discharge. It is assembled into an ultra-small 1.6x1.0x0.5mm lead-free DFN package. The small size and high ESD surge protection make PESDU4831P6 an ideal choice to protect cell phone, digital cameras, audio players and many other portable applications.

Features

- Ultra small package: 1.6x1.0x0.5mm
- Protects one data or power line
- Low clamping voltage
- 2-pin leadless package
- Complies with following standards:
 - IEC 61000-4-2 (ESD) immunity test
Air discharge: $\pm 30\text{kV}$
Contact discharge: $\pm 30\text{kV}$
 - IEC 61000-4-5 (Lightning) 170A (8/20 μs)
- RoHS Compliant

Dimensions and Pin Configuration

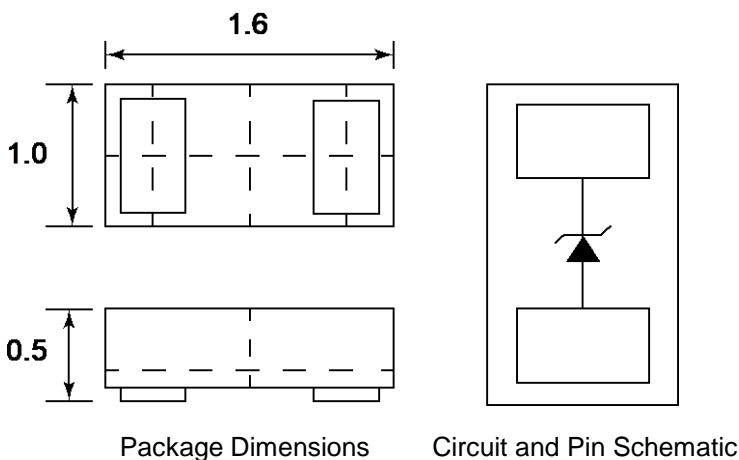

Mechanical Characteristics

- Package: DFN1610-2
- Case Material: "Green" Molding Compound.
- Moisture Sensitivity: Level 1 per J-STD-020
- Marking Information: See Below

Applications

- Mobile Phones
- Battery Protection
- Power Line Protection
- Vbat pin for Mobile Devices
- Hand Held Portable Applications

Marking Information

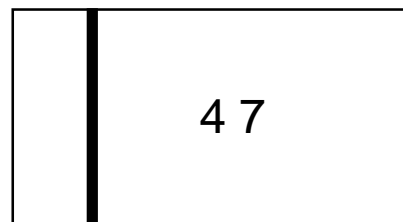

47 = Device Marking Code
Bar denotes cathode

Ordering Information

Part Number	Shipping	Reel Size
PESDU4831P6	3000/Tape & Reel	7 inch

Absolute Maximum Ratings (T_A=25°C unless otherwise specified)

Parameter	Symbol	Value	Unit
Peak Pulse Power (8/20μs)	P _{PK}	2550	W
Peak Pulse Current (8/20μs)	I _{PP}	170	A
ESD per IEC 61000-4-2 (Air)	V _{ESD}	±30	kV
ESD per IEC 61000-4-2 (Contact)		±30	
Lead temperature	T _L	260	°C
Operating Temperature Range	T _{OP}	-40 ~ +85	°C
Storage Temperature Range	T _{STG}	-55 ~ +150	°C

Electrical Characteristics (T_A=25°C unless otherwise specified)

Parameter	Symbol	Min	Typ	Max	Unit	Test Condition
Reverse Working Voltage	V _{RWM}			4.8	V	
Breakdown Voltage	V _{BR}	5.0	5.6	6.4	V	I _T = 1mA
Reverse Leakage Current	I _R			1	μA	V _{RWM} = 4.8V
Clamping Voltage	V _C		7	8	V	I _{PP} = 50A (8/20μs pulse)
Clamping Voltage	V _C		14	15	V	I _{PP} = 170A (8/20μs pulse)
Junction Capacitance	C _J		650		pF	V _R = 0V, f = 1MHz

Electrical characteristics ($T_A = 25^\circ\text{C}$, unless otherwise noted)

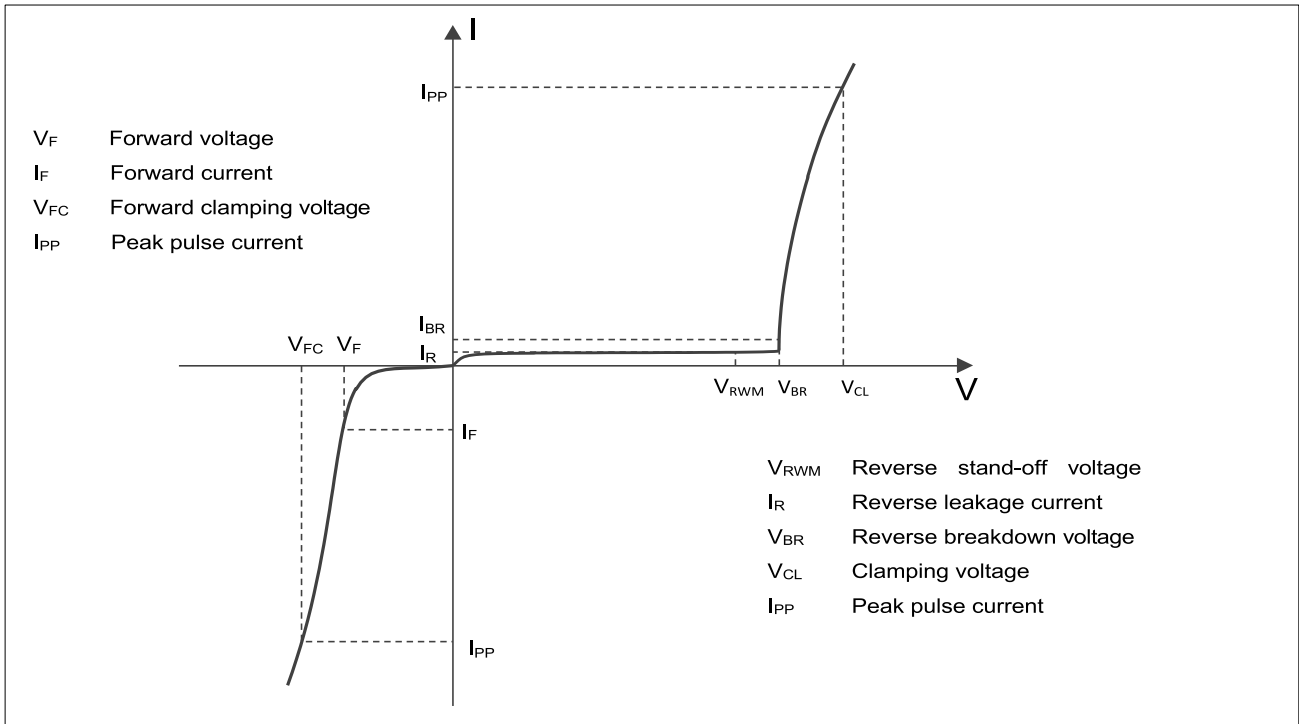

Definitions of electrical characteristics

Typical Performance Characteristics (T_A=25°C unless otherwise Specified)

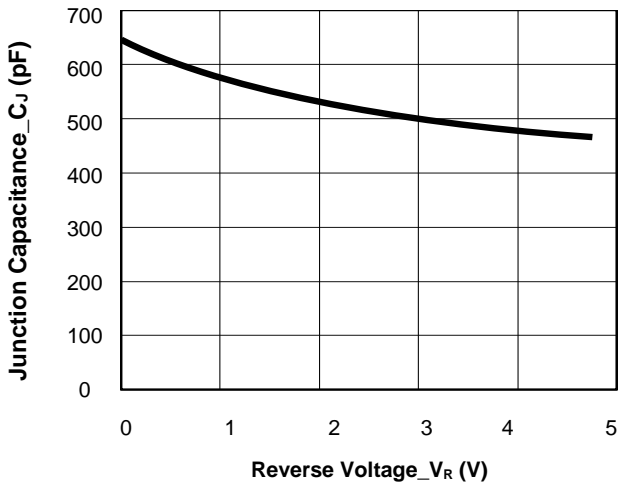

Junction Capacitance vs. Reverse Voltage

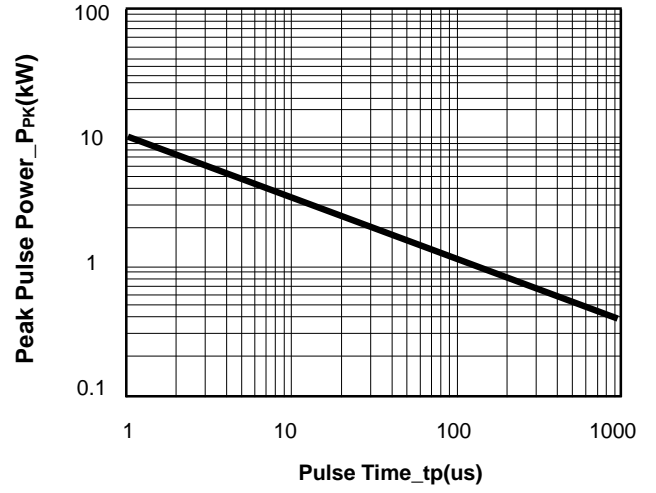

Peak Pulse Power vs. Pulse Time

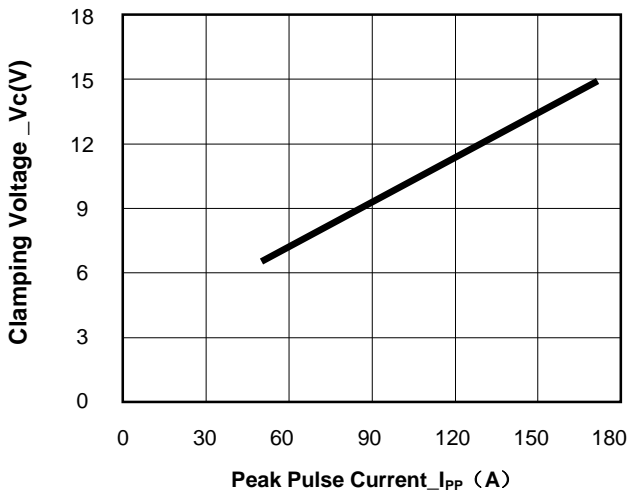

Clamping Voltage vs. Peak Pulse Current

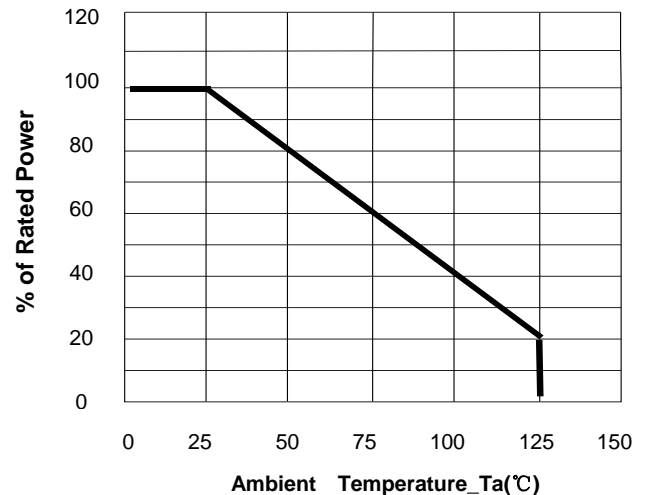

Power Derating Curve

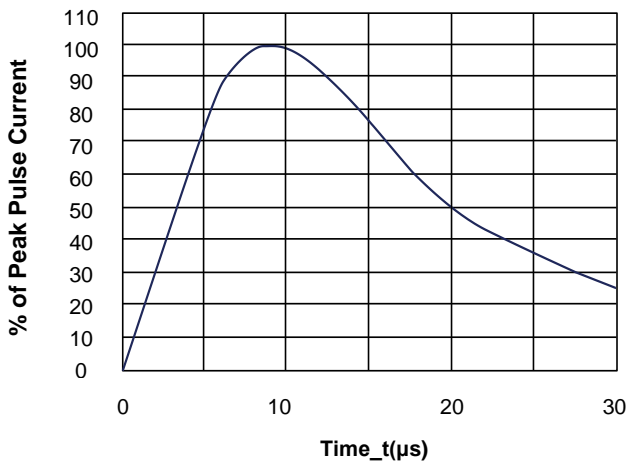

8/20μs Pulse Waveform

DFN1610-2 Package Outline Drawing

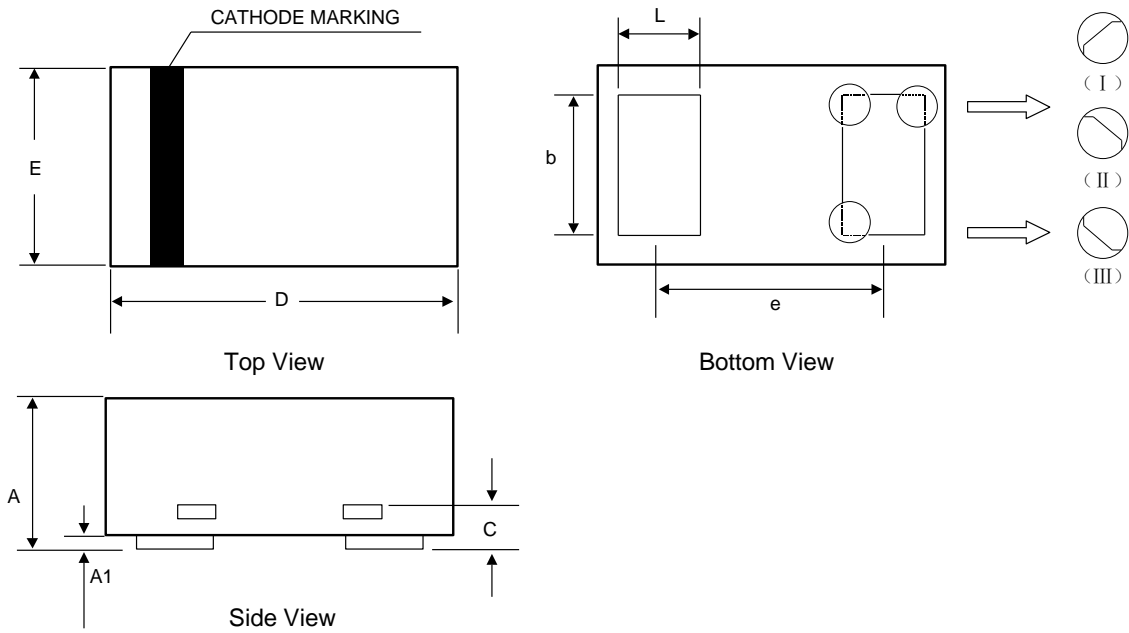

SYM	DIMENSIONS					
	MILLIMETERS			INCHES		
	MIN	NOM	MAX	MIN	NOM	MAX
A	0.45	0.50	0.55	0.018	0.020	0.022
A1		0.02	0.05		0.001	0.002
b	0.75	0.80	0.85	0.030	0.032	0.034
c	0.10	0.15	0.20	0.004	0.006	0.008
D	1.55	1.60	1.65	0.062	0.064	0.066
e	1.10 BSC			0.044 BSC		
E	0.95	1.00	1.05	0.038	0.040	0.042
L	0.35	0.40	0.45	0.014	0.016	0.018

Suggested Land Pattern

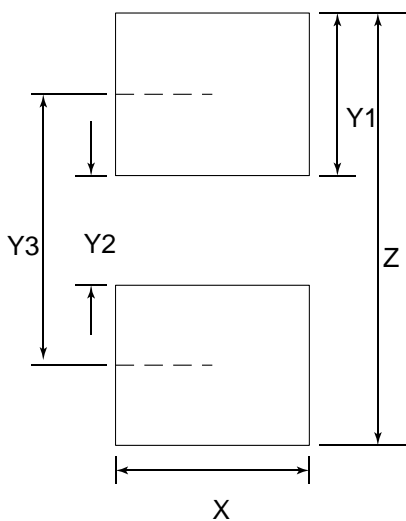

SYM	DIMENSIONS	
	MILLIMETERS	INCHES
X	1.00	0.040
Y1	0.62	0.025
Y2	0.60	0.024
Y3	1.22	0.049
Z	1.85	0.074

TAPE AND REEL INFORMATION

Reel Dimensions

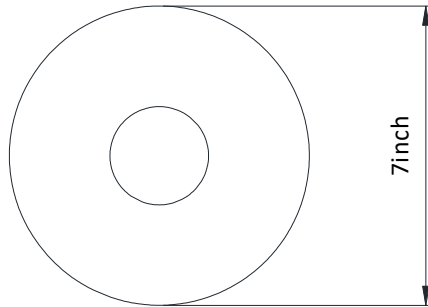

Tape Dimensions

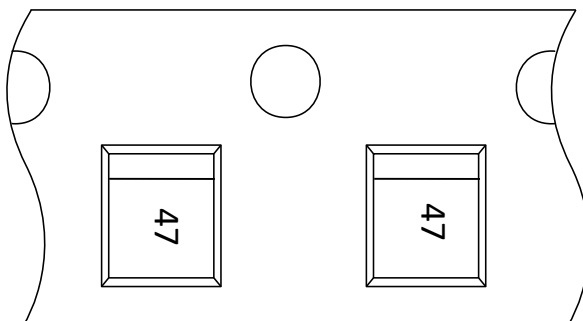
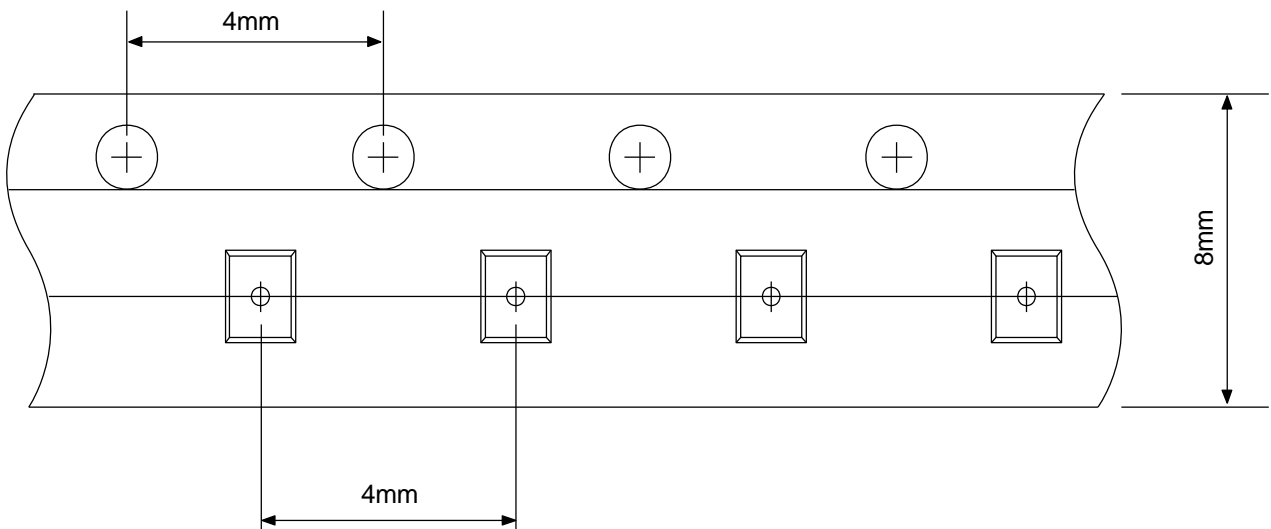

User Direction of Feed

IMPORTANT NOTICE

The information given in this document is believed to be accurate and reliable but shall in no event be regarded as a guarantee of conditions or characteristics. PN-Silicon assumes no responsibility for any errors in this document, or for the consequences of use of such information nor for any infringement of patents or other rights of third parties which may result from its use. No license is granted by implication or otherwise under any patent or patent rights of PN-Silicon.

The product listed in this document are designed to be used with ordinary electronic equipment or devices and are not authorized to used with equipment or devices which require an extremely high level of reliability and the malfunction of with would directly endanger human life (such as medical instruments, aerospace machinery, nuclear-reactor controllers, automotive and other safety device.)

The **PN SILICON** logo is a registered trademark of PN-Silicon co., ltd which reserves the right to make changes to the product or this document at any time without notice. Buyers should obtain the latest relevant information before placing orders and should verify that such information is current and complete. PN-Silicon makes no warranty, representation or guarantee, express or implied, regarding the suitability of its products for any particular purpose. All rights reserved.